

# JUUNOO

## TECHNICAL DOCUMENTATION

Version 2026 01 19 – ENG metric

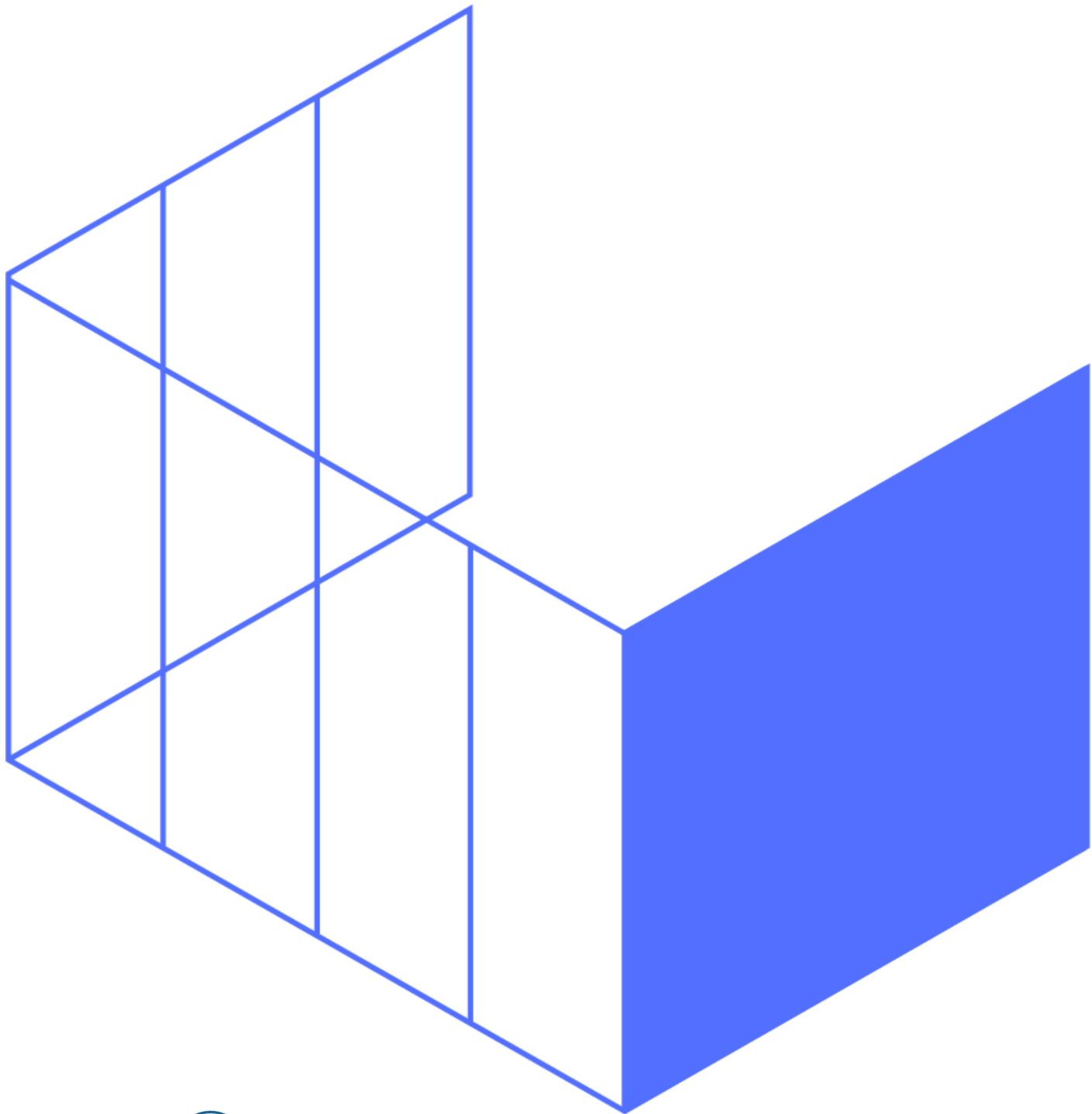

reddot winner 2020



## Contents

<b>Contents</b>		<b>0</b>
<b>1 Short disclaimer</b>		<b>1</b>
<b>2 Modules</b>		<b>2</b>
2.1 Recognizing the three different modules: I-, C- en D-module	2	
2.2 Working with I-Modules	3	
2.3 Working with C-Modules	6	
2.4 Starting point	7	
2.5 Fixing the modules	9	
2.6 High walls	11	
2.7 Corners	12	
2.8 Doorway: D-set	13	
2.9 Combining with glass windows, glass doors and special components	19	
2.10 Connection to a drop ceiling	20	
<b>3 In the wall</b>		<b>24</b>
2.11 Installation on a pitched roof	23	
3.1 Acoustic insulation	24	
3.2 Cabling	24	
3.3 Electrical outlets	25	
<b>4 Panels</b>		<b>27</b>
4.1 Mounting of panels on JUUNOO	27	
4.2 Mounting BaseClick & AcouClick	29	
4.3 Disassembling BaseClick & AcouClick	31	
4.4 Panel around a door	32	
4.5 Painting of BaseClick or Acouclick	33	
4.6 Textile finish or whiteboard sheets	34	
4.7 Drywall panels	35	
4.8 OSB and Drywall Combination	38	
4.9 Partition wall panels + click panels	38	
4.10 Fixing items to a JUUNOO wall	39	
4.11 Acclimating the click panels	40	
5.1 Outer corners	41	
5.2 Inner corners	43	
5.3 Acoustic decoupling of a wall	44	
<b>5 Finishes</b>		<b>41</b>
5.4 Fixation	45	
5.5 Edge finishing	47	
5.6 Ceiling and wall connection	49	
5.7 Connection to an existing building	50	
5.8 Connection to the window	56	
<b>6 Doors</b>		<b>57</b>

<b>7</b>	<b>Glazing</b>		<b>61</b>
6.1	Installation of a standard, unpainted door	57	
6.2	Levelling a door	59	
<b>8</b>	<b>Dimensions</b>		<b>86</b>
7.1	General principle	61	
7.2	Installation	61	
7.3	Measuring a glass wall	83	
7.4	Additional information on acoustics	85	
8.1	I-module dimensions	86	
8.2	C-module dimensions	86	
8.3	Generic dimensions of a wall	87	
8.4	D-set dimensions: for a single door	87	
8.5	DD-set dimensions: for a double door	87	
8.6	BaseClick dimensions	89	
8.7	AcouClick dimensions	90	
8.8	Dimensions glass wall	91	
<b>9</b>	<b>Sustainability</b>		<b>94</b>
8.9	AutoCAD, Revit, BIM models	93	
9.1	Materials used	94	
9.2	Reusability	96	
9.3	Buyback warranty	96	
<b>10</b>	<b>Test reports</b>		<b>101</b>
10.1	Full walls: Acoustic test reports – summary – daidalos peutz	101	
10.2	Glazed walls: Acoustic test reports - summarized - daidalos Peutz	105	
10.3	Impact test reports – WTCB	108	
10.4	Full walls: FEM analysis – strength – Indurium	109	
10.5	Full walls: Fire resistance classification – Warrington Fire – EI60	110	
10.6	Unilin click panel – JUUNOO technical validation	111	
10.7	Equivalent replacement of Cyproc® Metal Stud® by JUUNOO	112	
<b>11</b>	<b>Disclaimer</b>		<b>113</b>

## 1 Short disclaimer

Regularly check if you have the most up-to-date version of this technical documentation. This can be found at [www.juunoo.com](http://www.juunoo.com).

The full disclaimer can be found at the end of this document at page 113.

## 2 Modules

Recognizing the three different modules: I-, C- en D-module

2.1

I-module

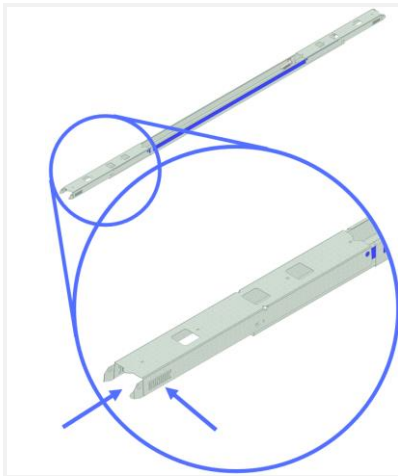

- Compact:
- JUUNOO-logo
  - Flaps sticking out



- Open:
- Shape of capital letter I

C-module

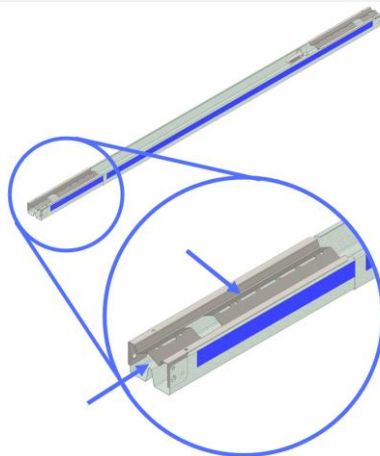

- Compact:
- Serrated shape
  - No parts sticking out



- Open:
- Shape of capital letter C

D-module

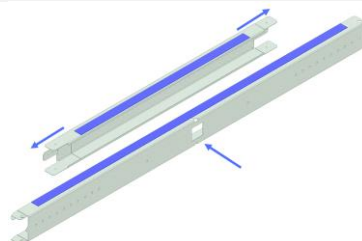

- Compact: 2 profiles
- 1 short = 2 profiles slided together
  - 1 long profile + central hole

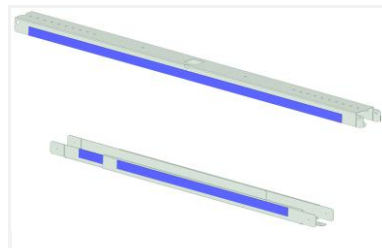

- Open:
- Not a lot of difference with compact set.

## Working with I-Modules

### 2.2.1 Top and bottom of an I-module

2.2

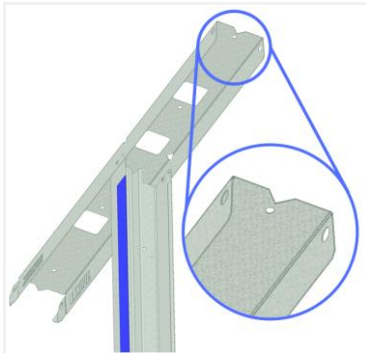

Top edge: contour in the shape of a "roof".

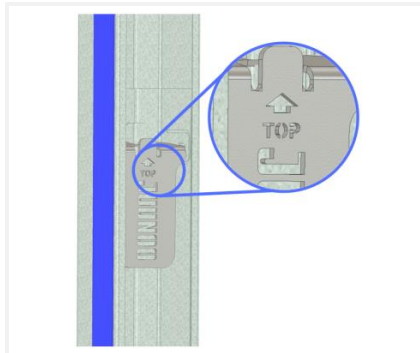

Middle: "TOP" points upwards

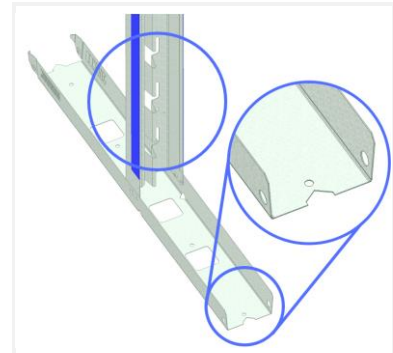

Bottom edge: contour in the shape of a "house".

### 2.2.2 Installing the I-Module



The modules are delivered folded.



Unfold the horizontal profiles.



Open the Quicksan and slide the module open.



Clamp the module between the floor and ceiling by closing the Quicksan. Fix the module in place like in chapter 2.5.

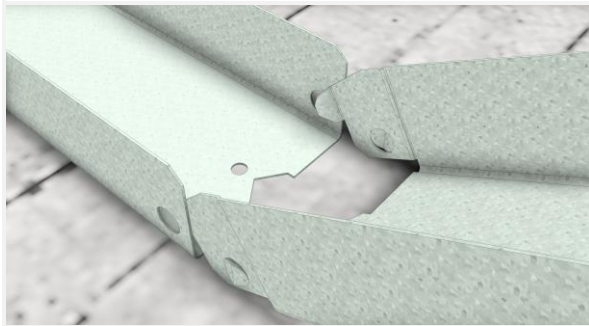

Connect the second module to the first.  
The profiles have 'flaps' to facilitate the alignment

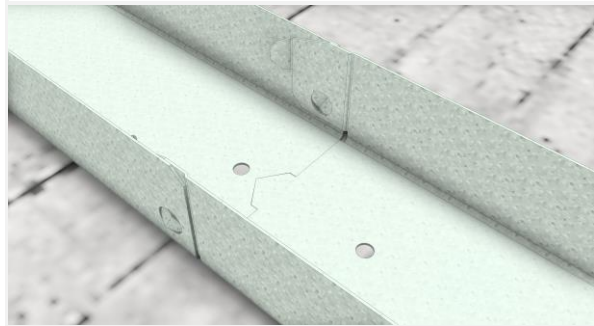

Click the horizontal profiles together.



Open the Quicksan and slide the module open.



Click the top horizontal profile into the previous parts.



Clamp and fix the module.



Carry on building!

### 2.2.3 Height adjustments: Quickspan

To temporarily hold the module in place, the module is clamped between the floor and ceiling. This leaves the hands free to eventually fix the module with screws.

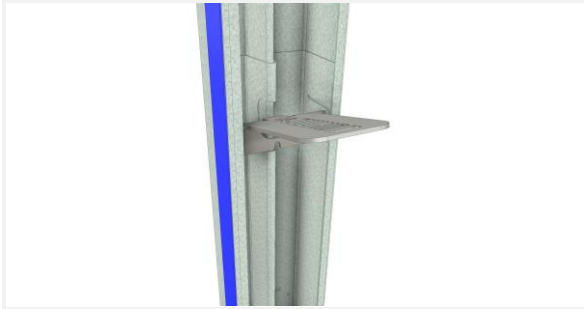

With an open Quickspan you can infinitely adjust the height of a module.

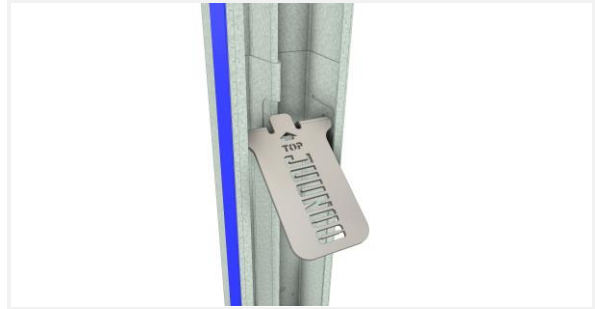

The Quickspan acts as a lever so you can work smoothly.

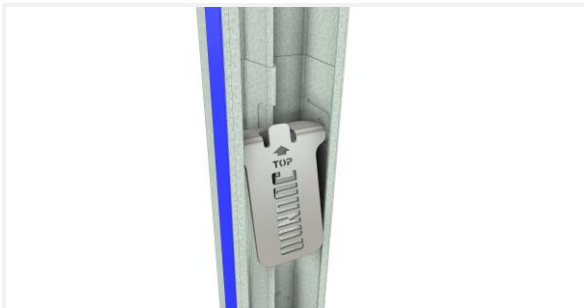

The modules slide open and clamp between the floor and ceiling.

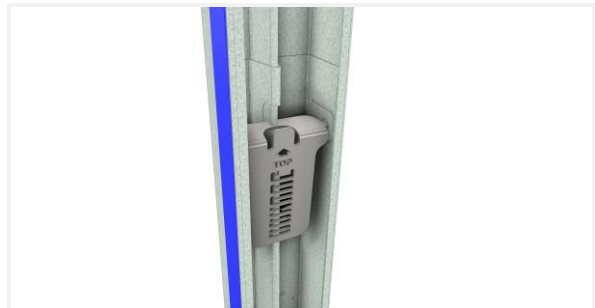

When the Quickspan lever is closed, the modules are tensioned and fixed in place.

## Working with C-Modules

### 2.3.1 Top and bottom of a C-module

The C-module does not have a roof and a house like module I. But there are other clues to distinguish the top from the bottom.

2.3

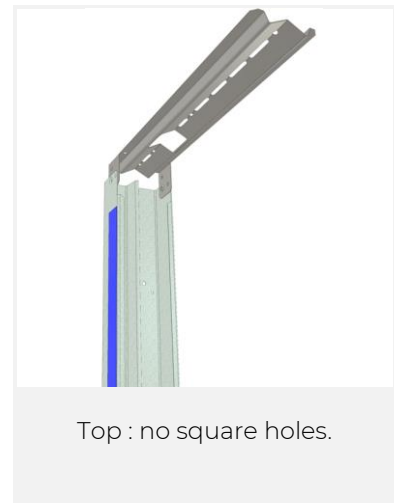
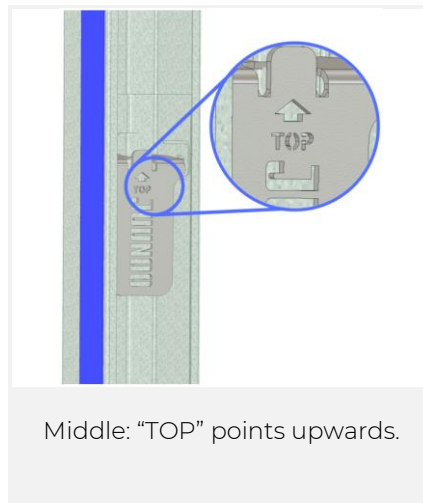
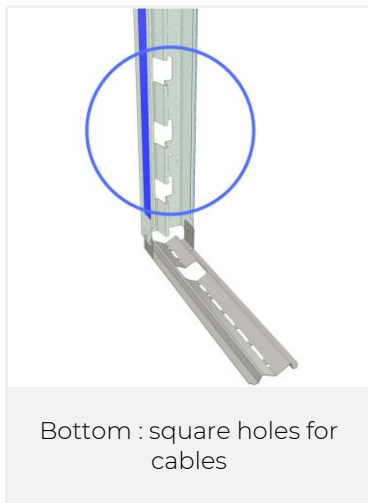

### 2.3.2 Installation of a C-module

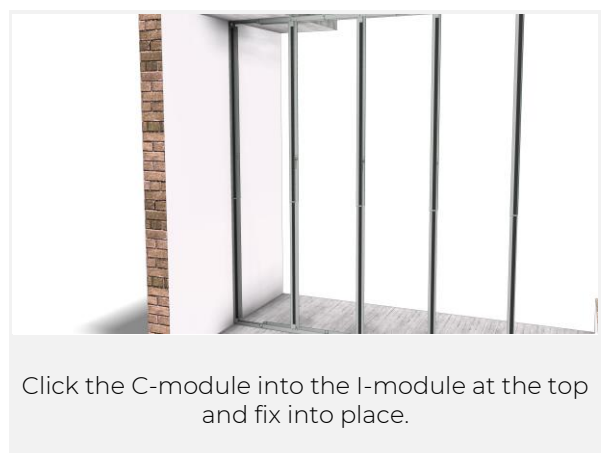
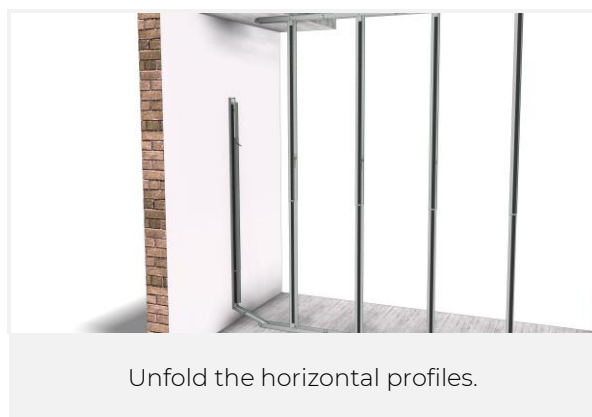

### 2.3.3 Height adjustments: Quickspan

To temporarily hold the module in place, the module is clamped between the floor and ceiling. This leaves the hands free to eventually fix the module with screws.

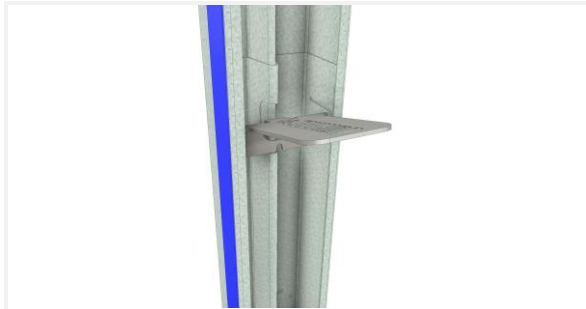

With an open Quickspan you can infinitely adjust the height of a module.

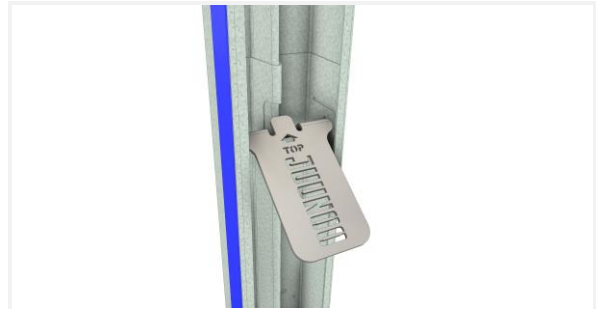

The Quickspan acts as a lever so you can work smoothly.

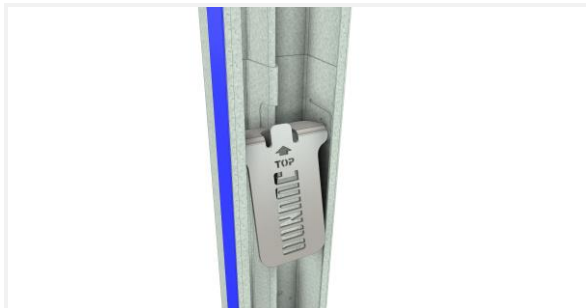

The modules slide open and clamp between the floor and ceiling.

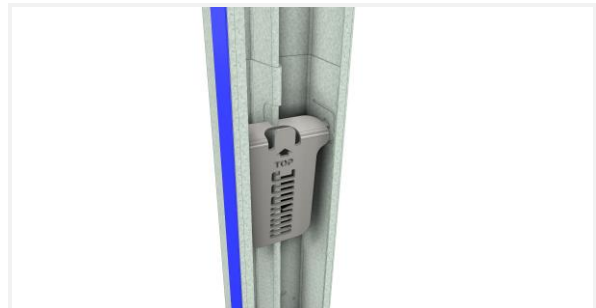

When the Quickspan lever is closed, the modules are tensioned and fixed in place.

2.4

### Starting point

#### 2.4.1 Symmetrical construction

With a JUUNOO wall the **I-modules** are **distributed centrally** over the wall so that the distance to the I- and C-modules is the same at both ends of the wall.

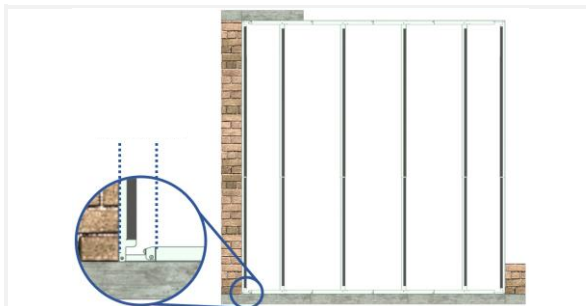

I-modules are central.

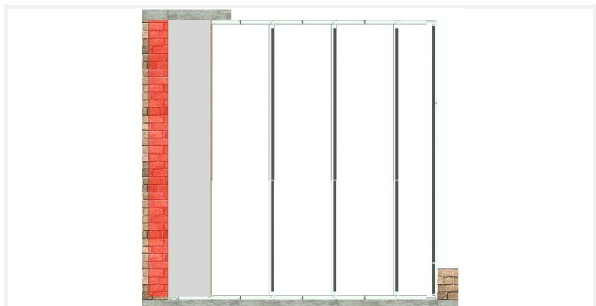

Start and stop panels are cut to size.

## 2.4.2 Determining where to place the start module with a tape measure

Using a tape measure means that a group of I-modules can be theoretically shifted along the length of the wall to see how they can be built up symmetrically.

This method is also very suitable when, for example, ventilation pipes must fit between two modules.

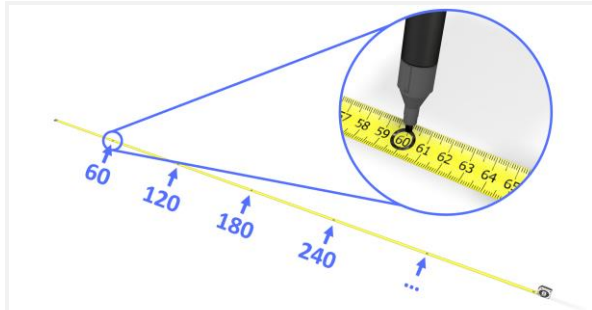

On a tape measure, circle all the multiples of 60 cm (23 5/8").

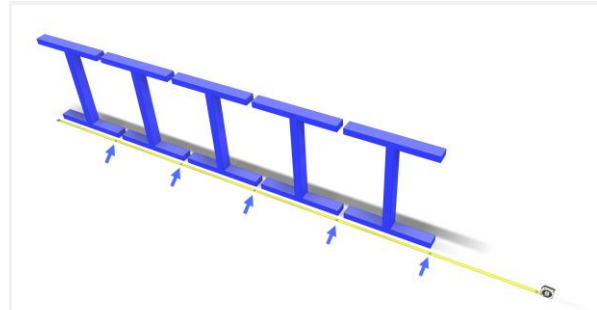

These distances represent the widths of the horizontal profiles of the I-modules.

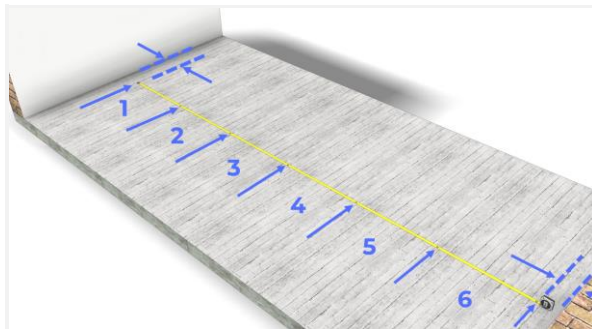

Extend the tape measure and count how many modules fit within the available space. Shift the tape measure so there is equal space on both ends between the measure and the wall.

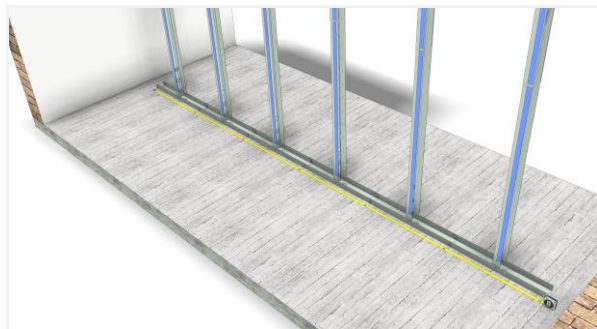

Once the tape measure is in the correct position, the modules can be aligned with the markings on the measure.

## 2.4.3 Calculate where to place the start module

If the tape measure is too short it can be useful to determine the start position manually as follows:

- Measure the length of the wall in cm  
**example: length = 260 cm**
- Divide this length by 60 cm  
**example:  $260\text{cm}/60\text{cm} = 4.33$**
- Multiply the numbers after the decimal point by 30 cm  
**example:  $0.33 \times 30 \text{ cm} = 9.9 \text{ cm}$**

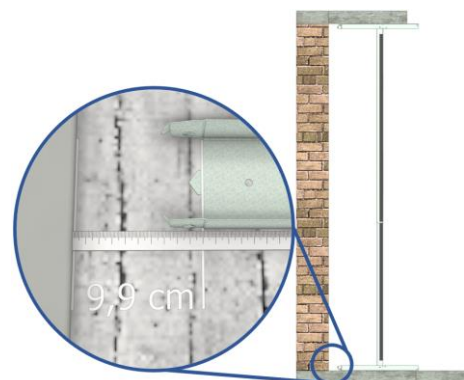

## Fixing the modules



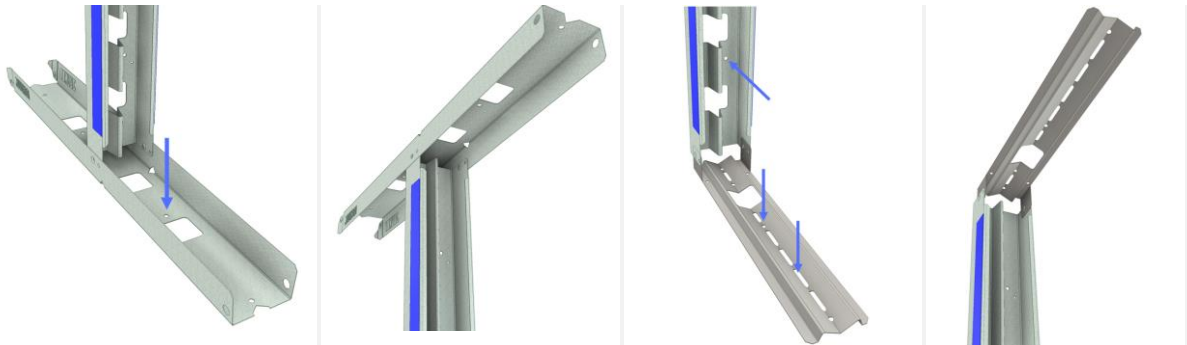

Quickspan is very effective in temporarily securing the modules. However, it is not strong enough to act as a replacement for individually fixing the modules into their surroundings.

### 2.5.1 Fixing with screws

- 2.5 The modules have pre-drilled holes at the top and bottom ( $\varnothing$  6 mm). All that is needed for each module is to fix it once at the top and once at the bottom with screws. Depending on the application, several screws can be used.



Depending on the material against which the modules are being fixed, you might need to use a specific type of screw. *Tip:* use screws without countersunk heads.

Type of screw (suggestion)	Substrate
<p>Anchor 5 x 30 mm</p> 	Concrete, tiles, etc.
<p>Wood screw 3.5 x 13 mm</p> 	Wood, laminate, etc.
<p>Self-drilling screws 4 x 25 mm</p> 	Technical floor with metal layer
<p>Tek screw 4.2 x 13 mm</p> 	Metal studs, other JUUNOO modules

## 2.5.2 Fixing bottom profiles with JUUNOO Glue

The wall can be fixed to the floor without causing damage. For this purpose, **JUUNOO Glue** is used. This is a double-sided tape with very high adhesive strength, which can also be removed without leaving adhesive residue.

Please note that this can only be used on the floor and not on the ceiling. Gravity ensures an extremely strong bond. When bonding to the ceiling or adjacent walls, this effect does not apply, resulting in a weaker connection.

Suitable for:

- Polished concrete
- Parquet and laminate
- Vinyl and PVC
- Smooth ceramic tiles

Important notes:

- Before application, ensure that both **the substrate and the modules are free of dust and grease.**
- In general, installation using JUUNOO Glue takes longer than screwing.
- Floors on which this method cannot be used:
  - o Carpeted floors
  - o Rough concrete
- Modules positioned next to a door must still be screwed into the floor.

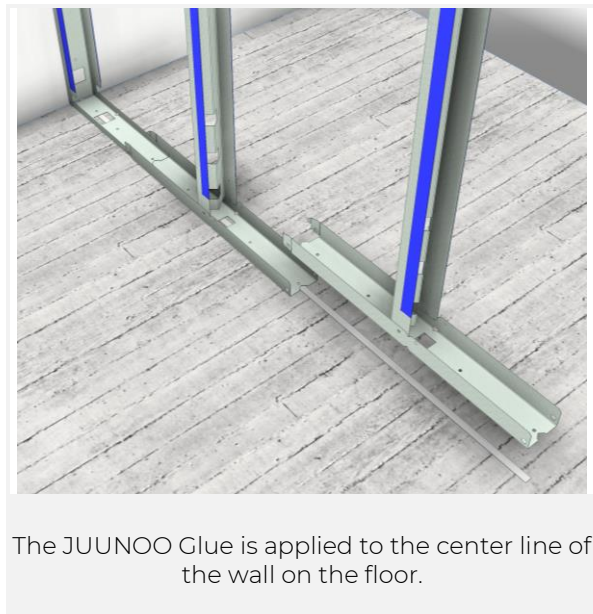
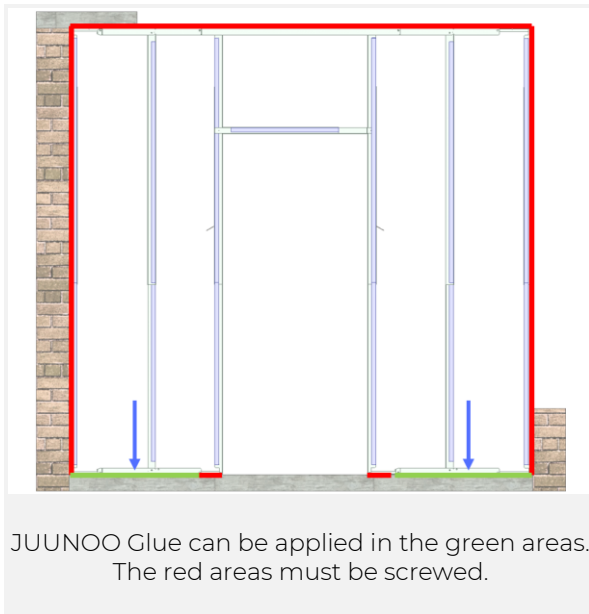

## High walls

The installation process for a high wall is identical to that of a normal wall.

2.6

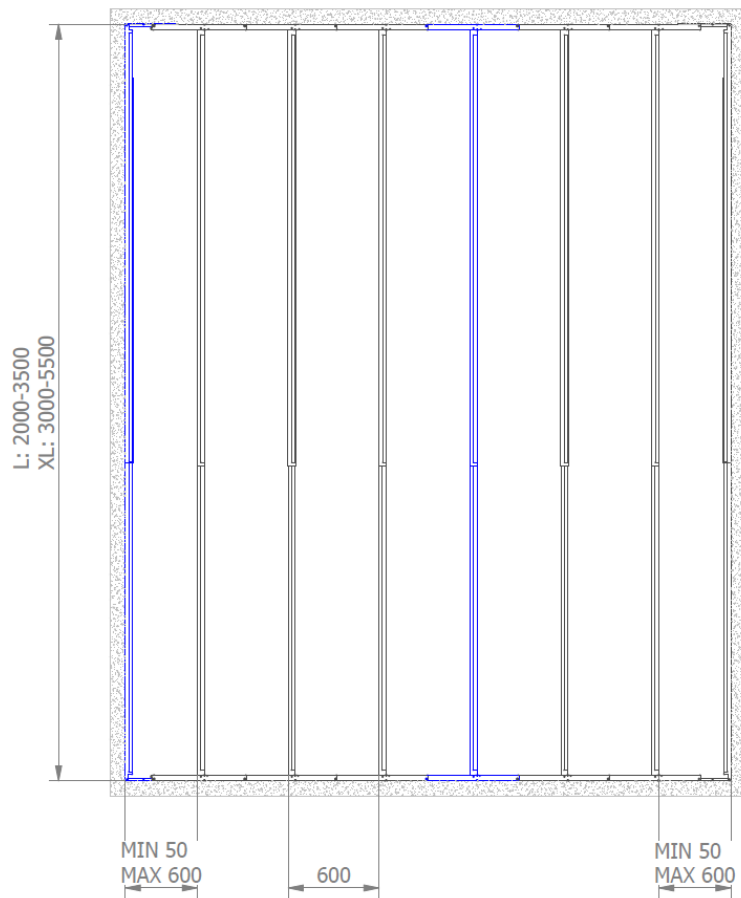

## Corners

### 2.7.1 Mounting angle: detail

Two JUUNOO C-modules can easily be placed at an angle. It is recommended that the panels of one wall continue between the 2 C-modules.

2.7

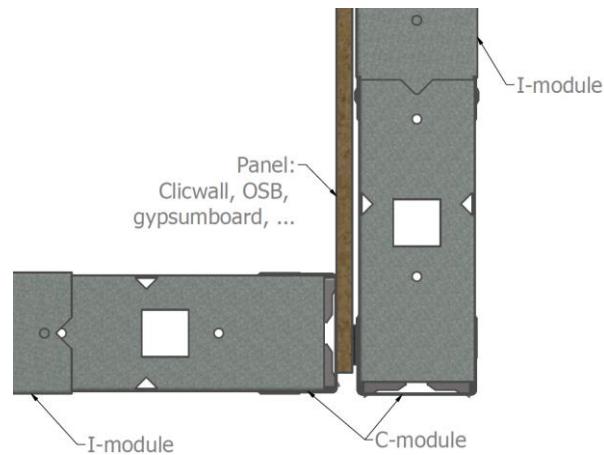

### 2.7.2 Construction method

We recommend that you only fix the C-module of the connecting wall in the corner once the panel has been mounted. For example, one construction team can install modules, and another can install the panels.



Position and fix 1 module structure.



Position the angled structure, but do not fix the adjacent C-module (blue) yet; slide it into the left.



Mount the panels to the 1<sup>st</sup> structure.



Slide the C-module against the panels and fix where necessary.

## Doorway: D-set

### 2.8.1 General principle for creating a doorway

2.8 A doorway is created by installing two C-modules and a door-set at the place where two I-modules would normally be installed. The two C-modules are on the left and right of the doorway. The door-set will be mounted above the doorway. The click-in panels continue along, with the JUUNOO blue tapes on the panels to the left and right of the door matching up with the tapes on the modules.

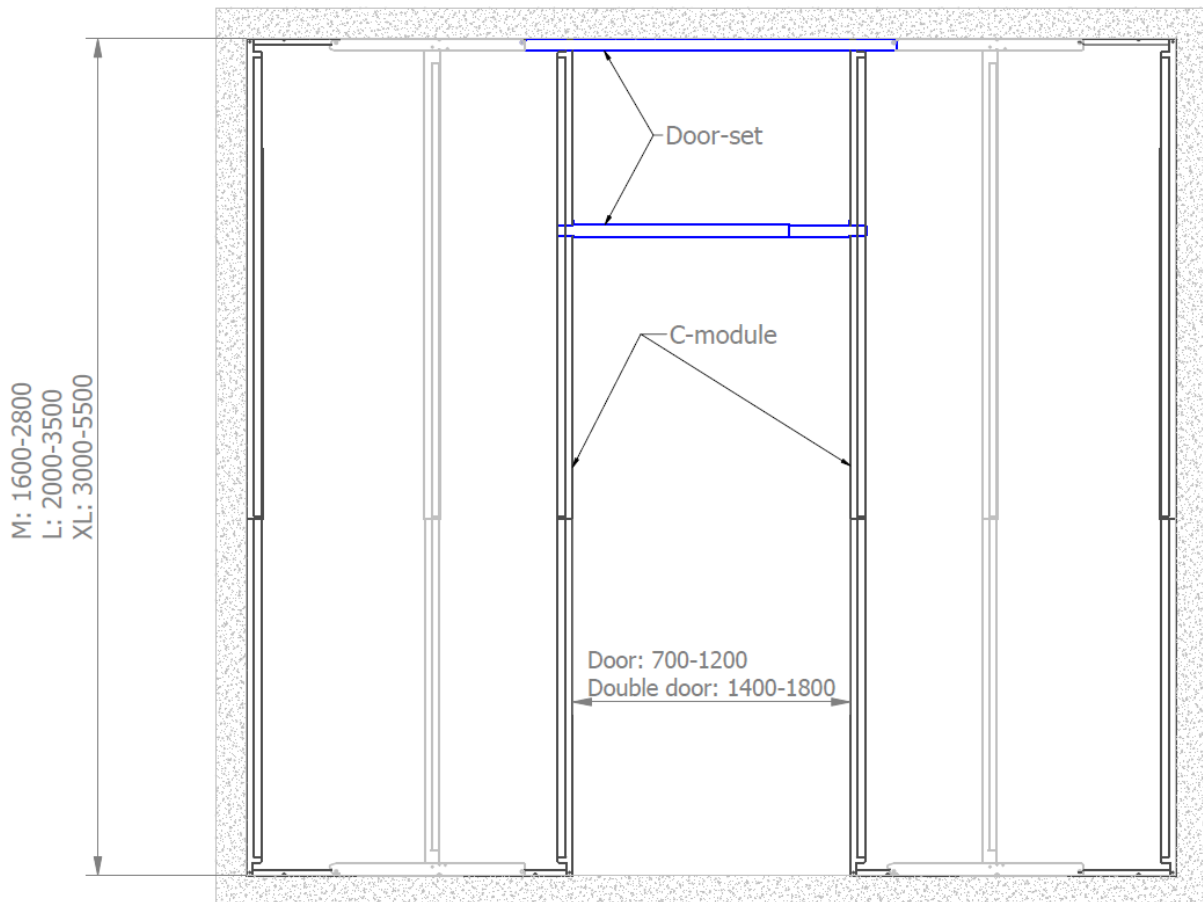

## 2.8.2 Positioning of standard doorway: D-set

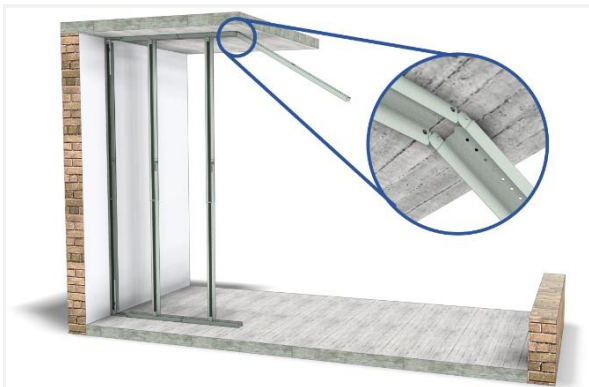

Click the large 120 cm door profile (= 2 I-modules) into the I-modules and fix it.

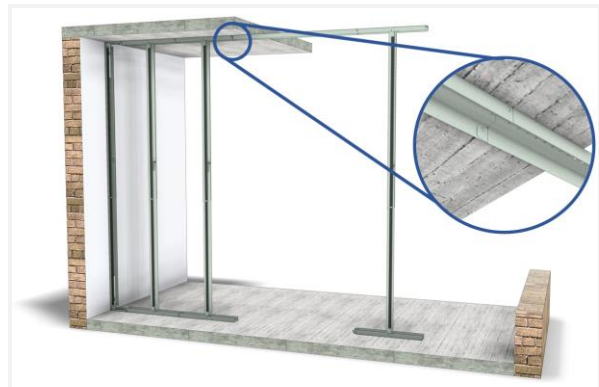

Click the next I-module into the door profile. Make sure it is level again.

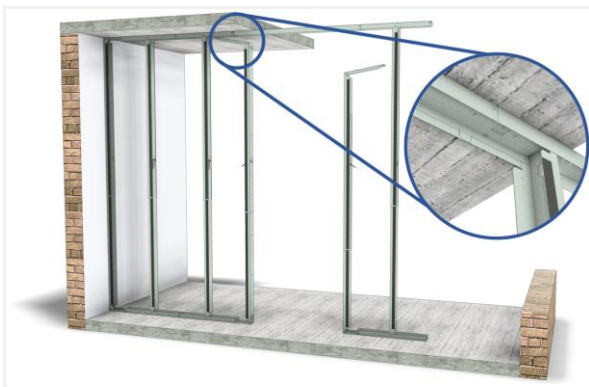

Place the 2 C-modules into position on the door. These slide into the door profile at the top, and slide into the I-modules at the bottom.



The placement of the C-modules/width of the door opening can be adjusted.

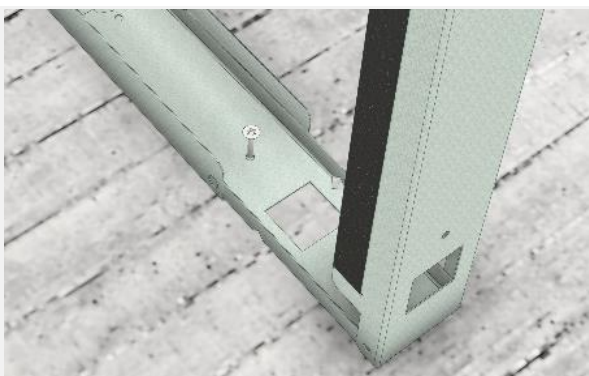

The C-module should preferably be screwed into the floor and ceiling.

When working with a doorway of 90 cm, the holes in the I- and C-modules will match. For other widths, you will need to drill a new hole.

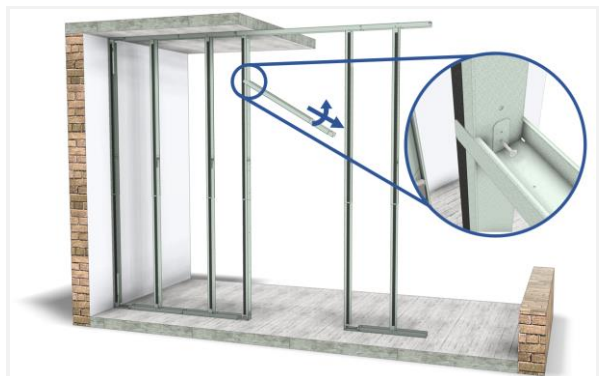

Attach the telescopic cross section to the C-modules at the desired height. The cross profile has a flap that can be fixed with self-tapping screws.



### 2.8.3 Using a tape measure to easily plan a door

A tape measure is the perfect tool for placing modules around doors or pipes. By laying out and moving the tape measure, you can very quickly see how everything interacts with each other.

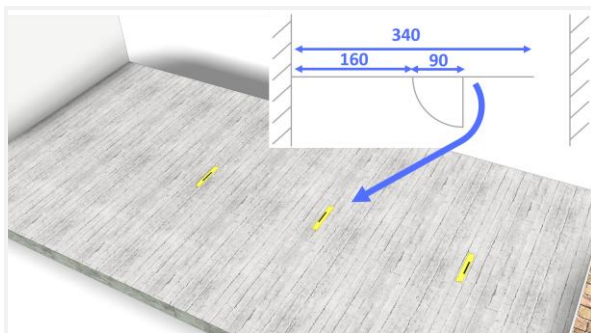

Mark doorways and ends of walls on the floor.

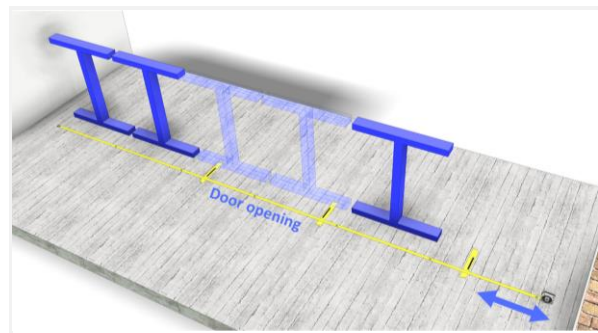

Note that only 2 theoretical I-modules overlap the doorway. If the base of a third I-module remains in the doorway, trim the base of that I-module.



Insert the I-modules. Insert a door top profile in the place of the door opening.



Now place the C-modules on the floor marking.

### 2.8.4 Door shifts to the left/right

In certain situations (wide doors, specific positioning of doors, etc.) the horizontal profile of the I-module may be inside the door opening. This can be cut off if necessary.

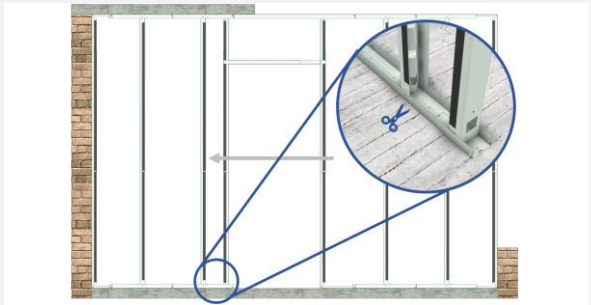

Door shifts to the left: this causes the I-module to the left of the door to protrude into the doorway. This piece must be cut off before the module is installed.

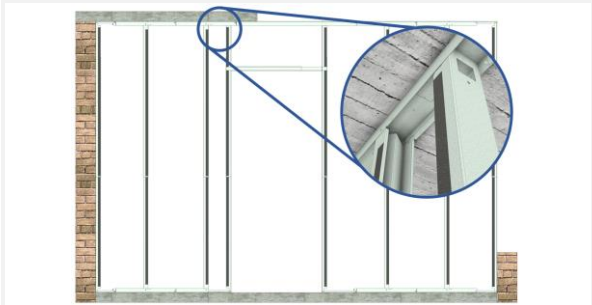

There will be no problems with the structure at the top.

To cut the I-modules, proceed as follows:



Unfold the last I-module.



Cut the raised edges on the horizontal profile at the mark indicated.



Fold the profile piece over and cut the bottom edge.



This way you will end up with an I/C-module.

## 2.8.5 Installing a door close to the wall

If the door is less than 60 cm from the wall, two C-modules will face each other without there being an I-module between them. In this case, we recommend folding the C-module against the wall and possibly shortening the C-module against the door.

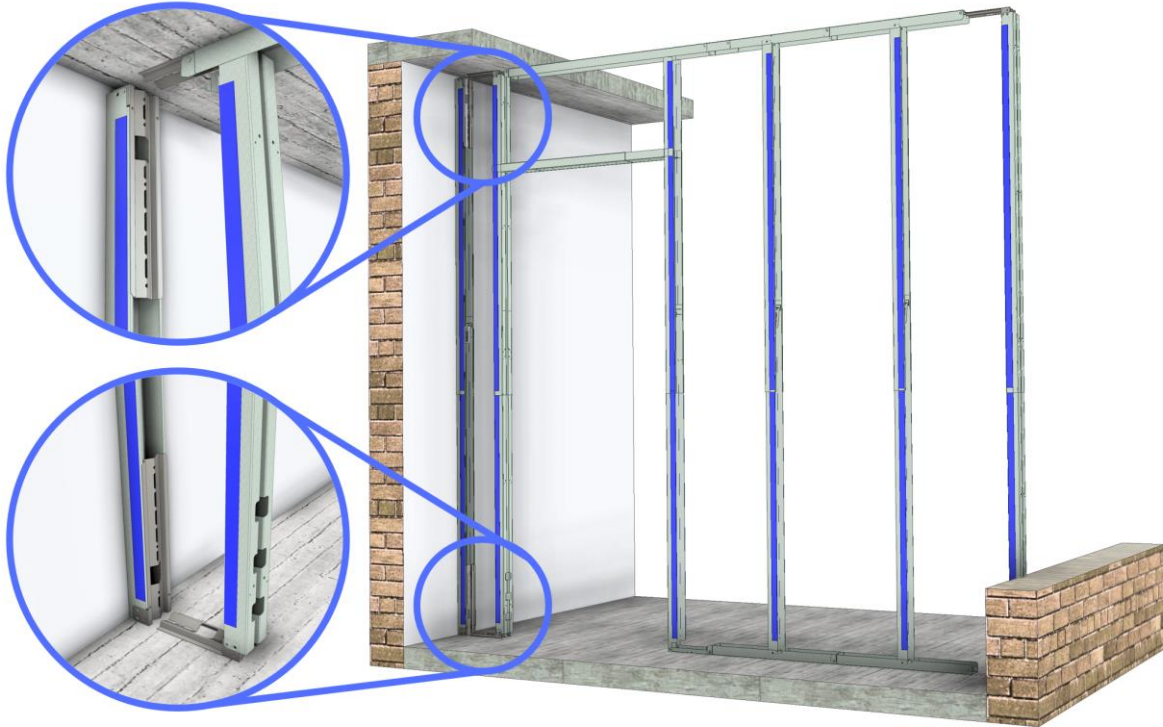

You shorten the C-module in a similar way in which you shorten the I-module.



Cut the raised edges on the horizontal profile at the mark indicated.



Fold the profile piece over and cut the bottom edge.



Of course, the profile can also be shortened in an unmarked area.

## 2.8.6 Door in high wall

Several cross sections are provided depending on the height. These give extra support to the joints of the panels that come above the doorway.

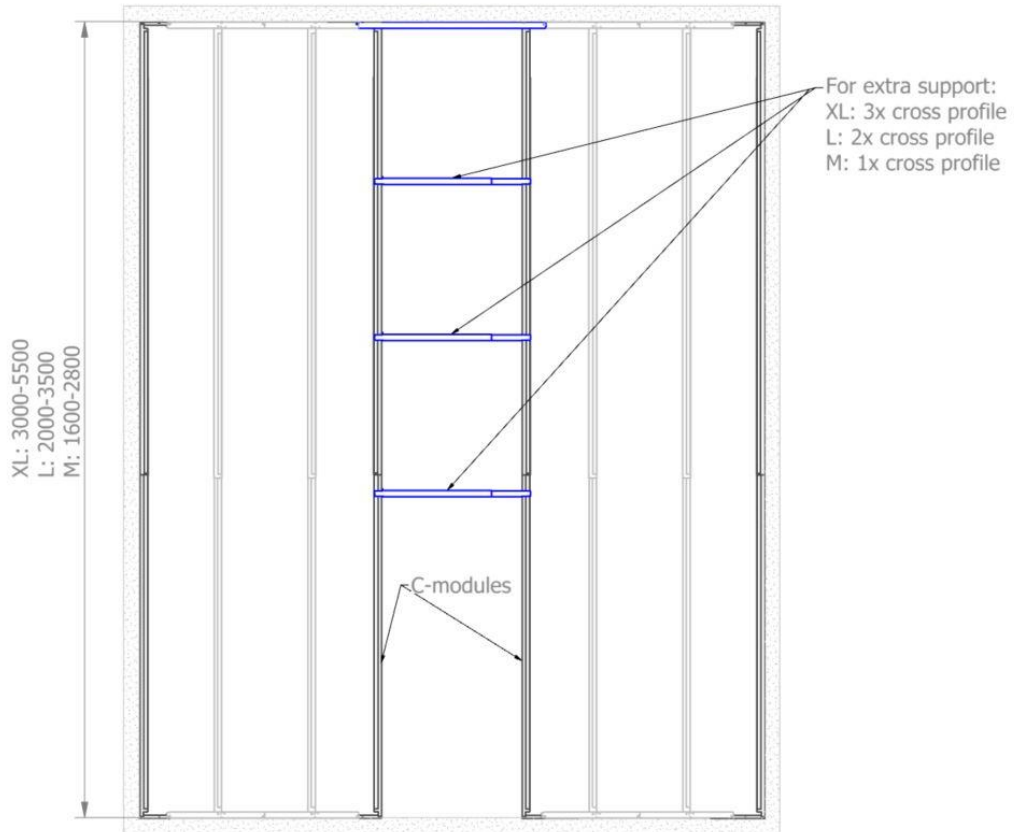

Combining with glass windows, glass doors and special components  
2.9.1 Generic dimensions: open wall with two C-modules

2.9

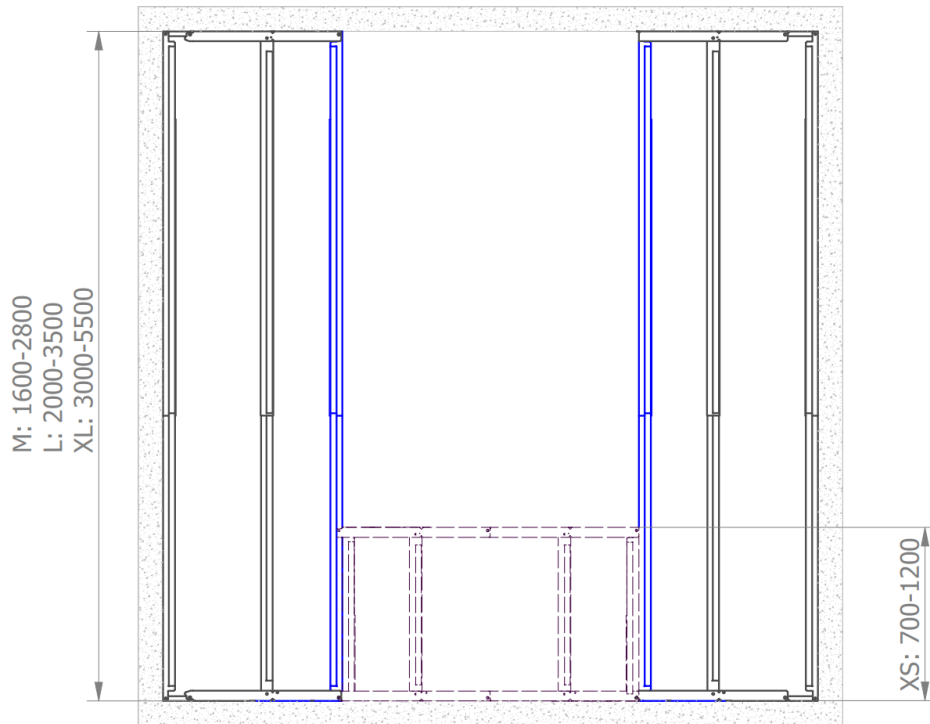

Small modules (Small, XS) are optional.

2.9.2 Installation of a combination wall

A JUUNOO wall can be easily combined with glass walls, windows, large doors or other types of openings. In locations where you must install other systems, the JUUNOO wall simply ends with a C-module.



## Connection to a drop ceiling

When installing the JUUNOO wall under a drop ceiling, vertical and horizontal reinforcements are recommended. It is also recommended that you work with bandrastrer grids. To avoid acoustic insulation problems, the space above the wall should be filled with an acoustic barrier (mineral plank) and the joints should be sealed with aluminium tape. When installing the acoustic barrier, the manufacturer's instructions must be followed.

2.10

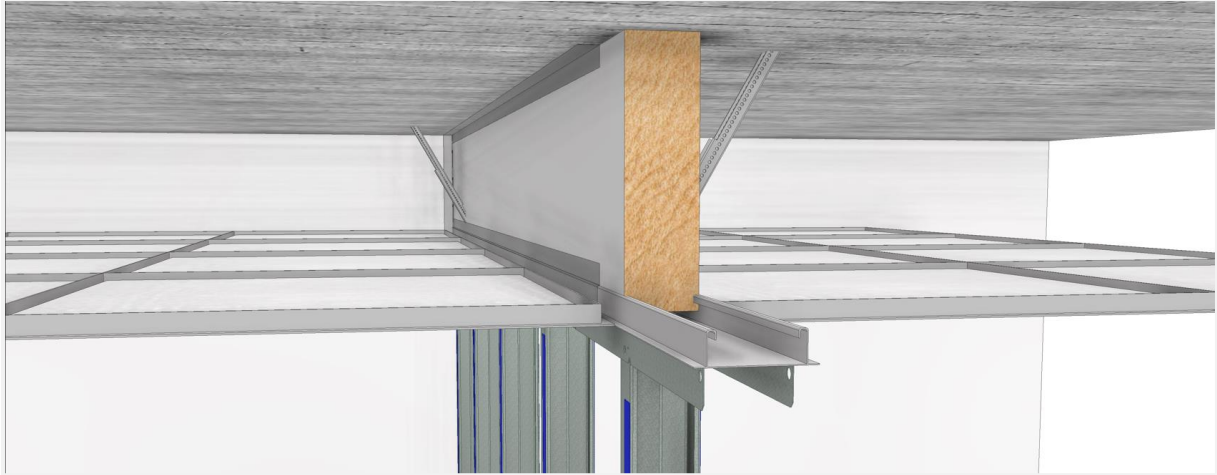

To hide holes in the profiles afterwards, these profiles are replaced or covered with a magnetic white strip.



If no bandrastrer is available, a wooden board can be first screwed to the ceiling profiles and then all the modules will be positioned against it. The panels cover the sides of the wood. Again, vertical and horizontal reinforcements are recommended. Watch out, without an acoustic barrier, sound goes over the wall very easily.

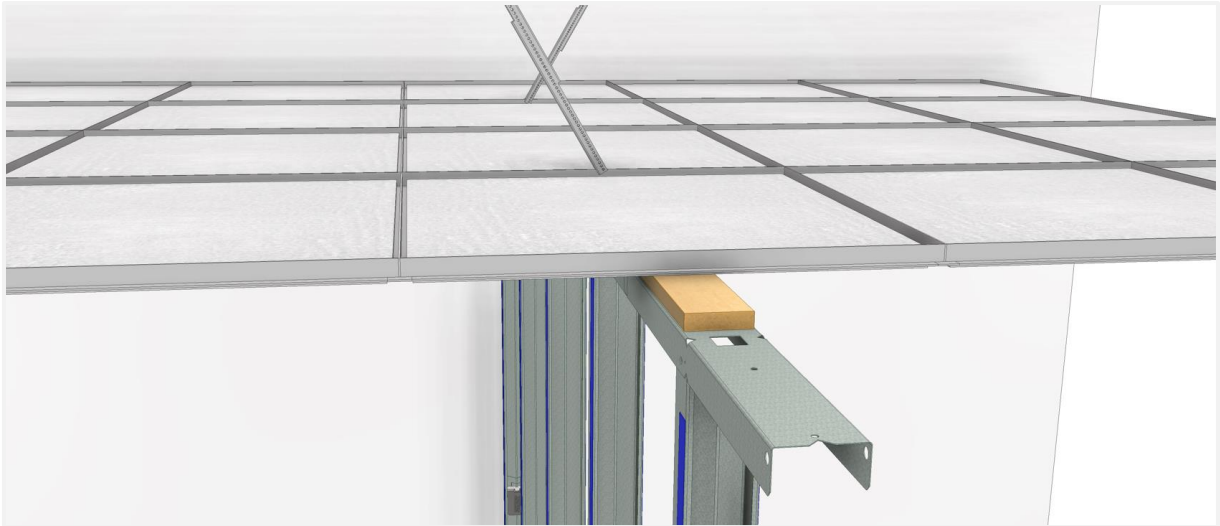

Some ceilings have a U-channel where a bolt (M6 or smaller) connects the modules. This solution doesn't damage the ceiling profiles.

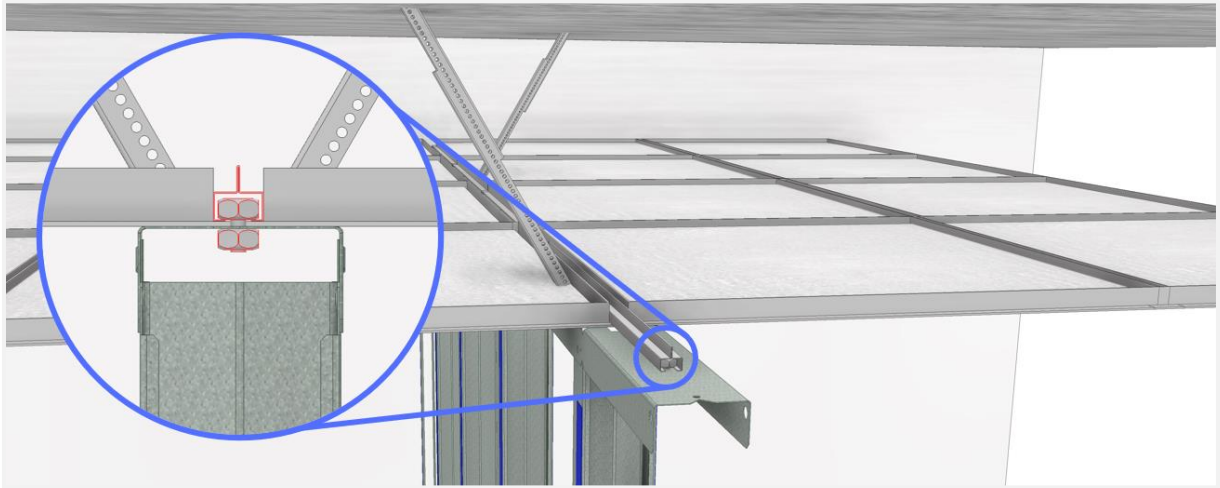

To achieve optimal acoustical performances, the wall can be installed against the ceiling first, whereafter the drop ceiling is installed against the wall. This is also required when installing a fire proof wall. This is a more robust structure, but less easy to adapt.



The modules are usually extended against the ceiling and only at that point are they tensioned. With a suspended ceiling, however, this would be difficult since the suspended ceiling would be pushed upwards. The following method is therefore used:

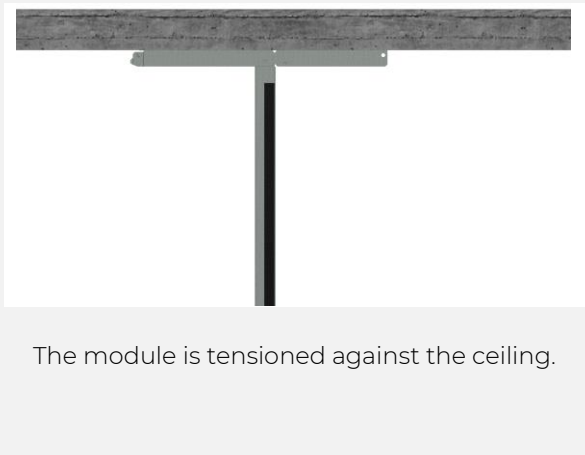

## Walls under a pitched roof

JUUNOO walls can be placed under a pitched or sloping roof if they are within the minimum and maximum range of the modules. If the dimensions are outside these limits, you will need to customise the solution.

- 2.11 When installing under a sloping roof, the I-modules must each be mounted vertically. They therefore do not click together in this set-up. At the top of the modules there must be at least 2 fixation points per module.

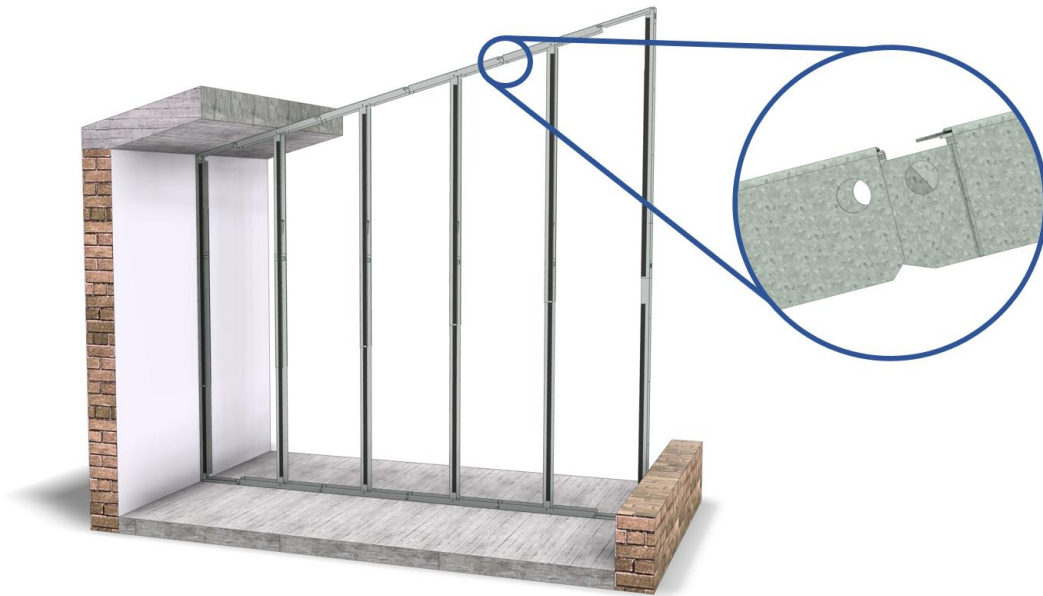

### 2.11.1 Minimum and maximum range under a pitched roof

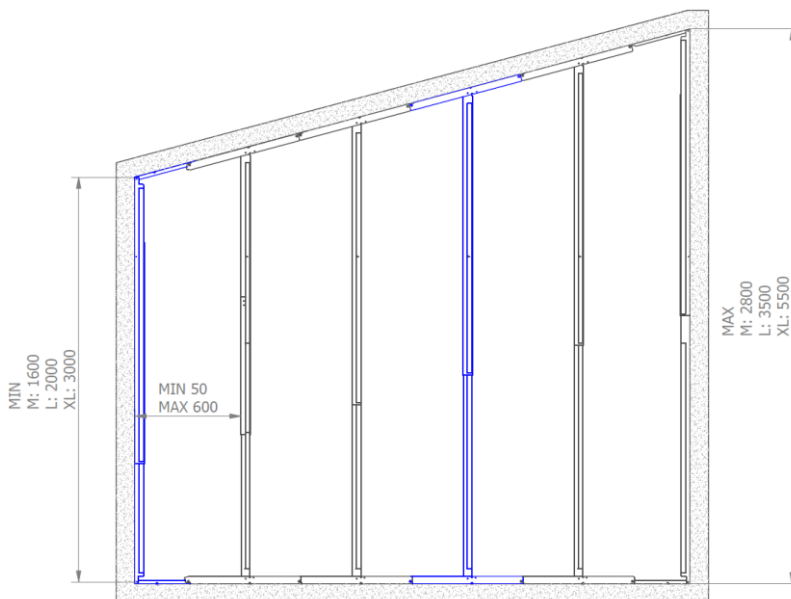

### 3 In the wall

#### Acoustic insulation

Standard panels fit perfectly between the vertical profile of the JUUNOO modules.

3.1



#### Cabling

- 3.2 In JUUNOO modules, we have provided 40 mm x 40 mm square openings for cabling. There is one opening each in the horizontal sections of the modules, and three openings in the vertical profile. Through the openings in the horizontal profiles, it is possible to pull cables through from a technical floor or drop ceiling into the JUUNOO structure.



Cables can run above and below the vertical profiles; the maximum height between the horizontal and vertical posts is 39 mm.



Electrical outlets

3.3 3.3.1 Placement

Electrical outlets can be easily installed in the JUUNOO wall.



Provide the necessary cables.



Attach the click panels to the modules.



Make a hole at the desired position.



Fix the flush-mounted socket in front of the socket.

### 3.3.2 Optimize reusability

It is recommended that the outlet is inserted in the central area of a panel, and not on a joint. This way you will not need to make a cut-out in the steel modules.

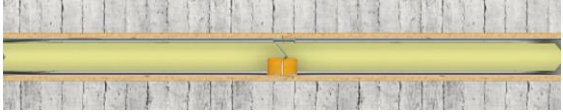
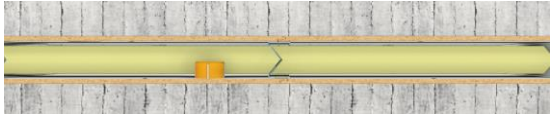
<p>Poor option Making a cut-out in the module will make it less usable. Also, due to the positioning, a hole is made in 2 panels.</p>	<p>X</p>	
<p>Good option A hole is only made in 1 panel. The module is not affected, which increases its reusability.</p>	<p>✓</p>	

### 3.3.3 Acoustic positioning

Take care when installing electrical outlets in an *acoustic wall*.

Sockets along both sides of a wall are a major 'acoustic leak' when installed directly opposite each other.

It is better to leave some space between two opposite outlets.

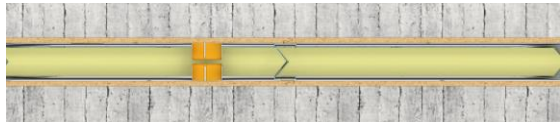
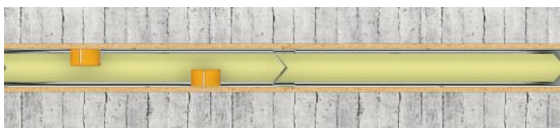
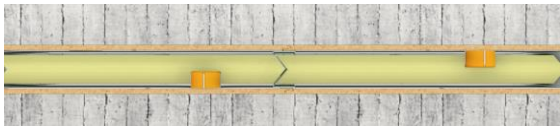
<p>Poor option: Sound can pass through the wall in one straight line.</p>	<p>X</p>	
<p>Better option: The sound must travel a greater distance through the acoustic batt inside.</p>	<p>✓</p>	
<p>Best option: The sound must travel a long way and will be partially absorbed by the modular style.</p>	<p>✓✓</p>	

There are plenty of pastes and foams, etc. on the market that you can use to make the back box etc. completely soundproof.

## 4 Panels

### Mounting of panels on JUUNOO

#### 4.1.1 Fastening with JUUNOO blue tapes

If using both JUUNOO and click panels, you can use JUUNOO blue tapes, a specially made hook and loop fastener. The advantage of using the JUUNOO tapes is the speed at which you can install them and how easy and simple it is to dismantle the panels from the wall.

- 4.1 However, we recommend adding screws for higher loads (> 5 kg per panel) or when using high acoustic panels. More on this at 4.2 and 4.10.

If you want to install other finishing panels with JUUNOO tapes, we recommend you contact the JUUNOO technical service or [info@JUUNOO.com](mailto:info@JUUNOO.com).

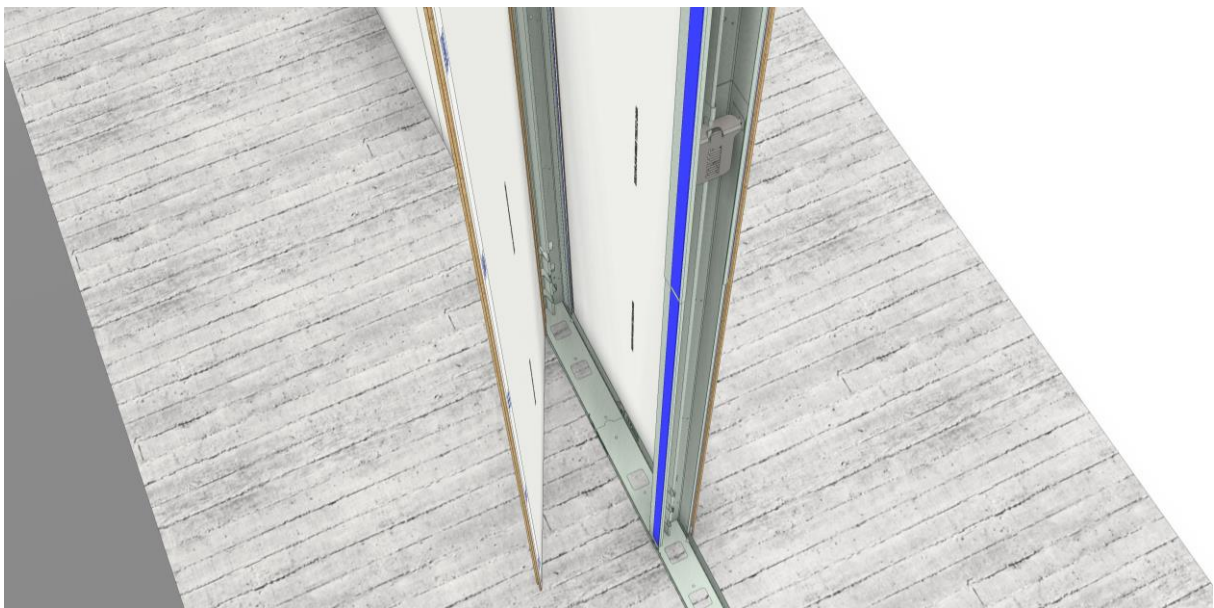

JUUNOO tapes can be provided by JUUNOO as standard on the modules and clicker panels. The contractor also has the option to purchase the tapes in rolls of 25m.



JUUNOO tapes, hook & loop



JUUNOO tapes, 25m roll

The JUUNOO tapes should be installed on a dust-free, degreased surface, at a temperature above 20 °C and at a humidity between 40% & 60%. After assembly, the JUUNOO tape must be pressed on firmly. The JUUNOO tape should be allowed to rest for at least 24 hours before loading.

#### 4.1.2 Fastening with screws

When screwing in the finishing panels, use the appropriate screws and spacing as prescribed by the panel manufacturer. This is the case, for example, with fire-resistant walls.



JUUNOO strongly recommends that you use a self-drilling version of these screws. This ensures that no lip is formed in the screw hole so that the profiles can continue to slide smoothly over each other after removal of the screw.



Self-drilling wood screw



Self-drilling  
drywall/plasterboard screw



Self-drilling Fermacell screw

#### 4.1.3 Additional information on acoustics and fire

In terms of acoustics, there is no noticeable difference between using screws or tape for attaching panels because the industrial JUUNOO blue tapes provide a very rigid connection. Information about test results can be found in chapter 10.1. For a fireproof wall, screws must be used on the panels against the structure since JUUNOO blue tapes are not made for this purpose.

## Mounting BaseClick & AcouClick

4.2

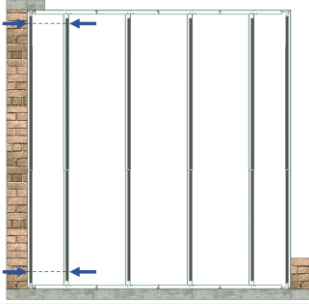

Measure the width of the wall up to the overall edge of the I-module.



Mark this on the starting panel.



Shorten the panel.

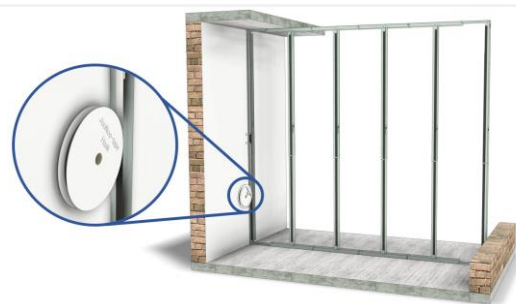

Stick JUUNOO tape (hook) on the C-modules.

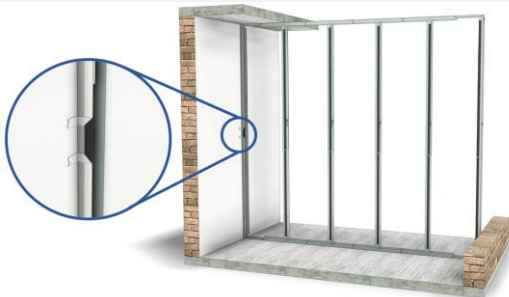

Tear the backing sheet in two and fold 2 flaps over against the wall.



Install the first panel against the wall and ceiling. Do not press the panel against the tape yet.

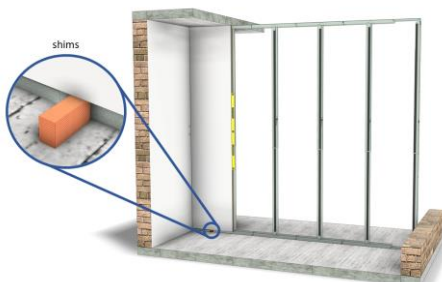

Using a spirit level, hang the first panel as straight as possible. Shims can be used for easier levelling and prevents rising damp.

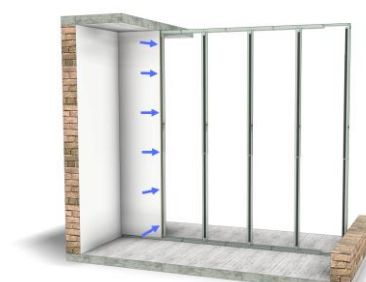

Once level, press the panel firmly.

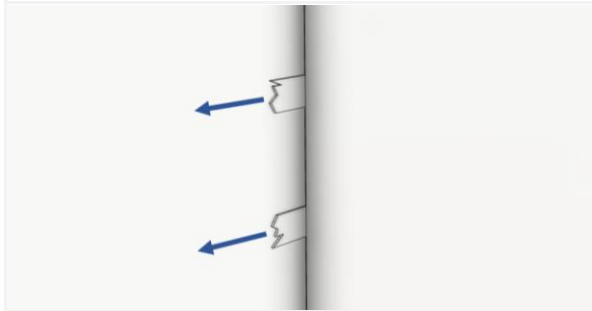

Pull off the backing sheet of the JUUNOO tape and press the panel.



Using Acouclick or heavier: reinforce the panel with two screws with drill point at the top, at 10 cm from each other.



Apply the 2<sup>nd</sup> panel at an angle of  $\pm 30^\circ$ .



The tongue of the 2<sup>nd</sup> panel hooks into the groove of the first panel. Move back and forth until closed.



Put the rest of the panels in place. Important when using AcouClick: put in every panel a screw in the groove on top.

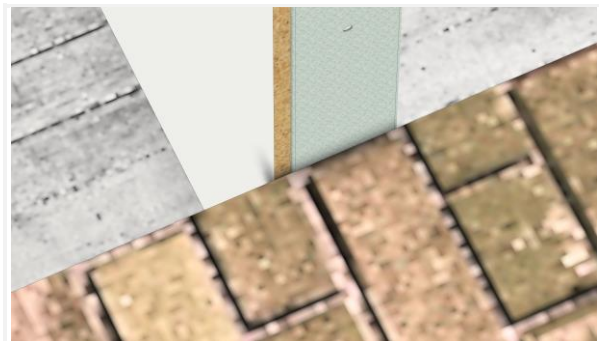

Saw the last panel to width. Provide at least 2 mm clearance between the wall and the panel.

## Disassembling BaseClick & AcouClick

4.3



A putty or filling knife will be needed to loosen the JUUNOO tape between the first panel and the JUUNOO modules.

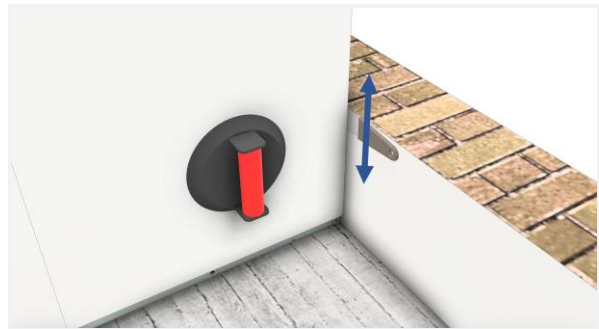

Hook the putty knife behind the click panel and score it up and down while pulling the panel backwards (using a suction cup if necessary).

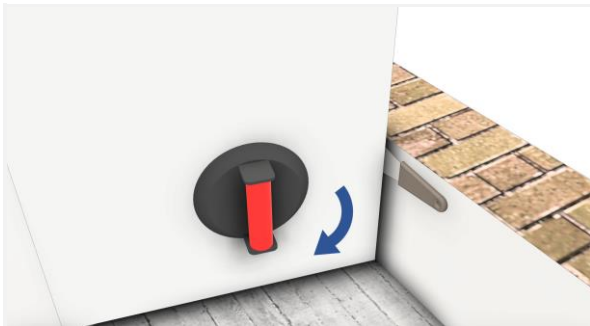

The panel can now be unfolded.

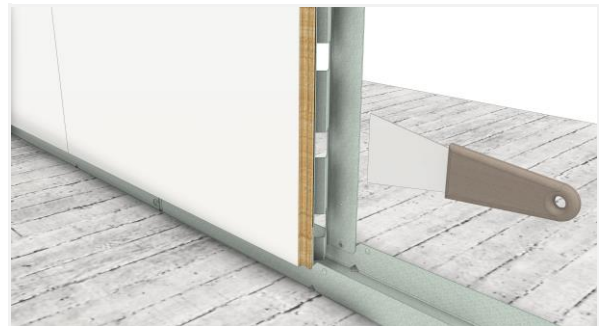

The rest of the click panels can be loosened with a straight spatula. Insert this between the panel and the module.

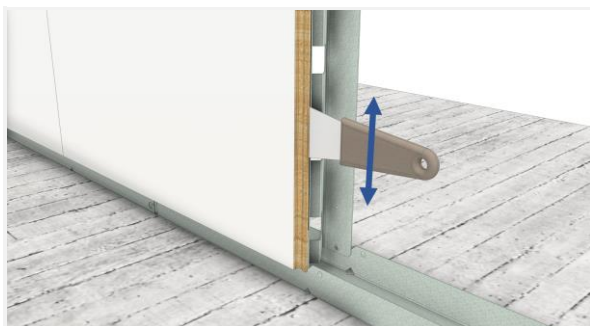

Move up and down to loosen the JUUNOO tape.

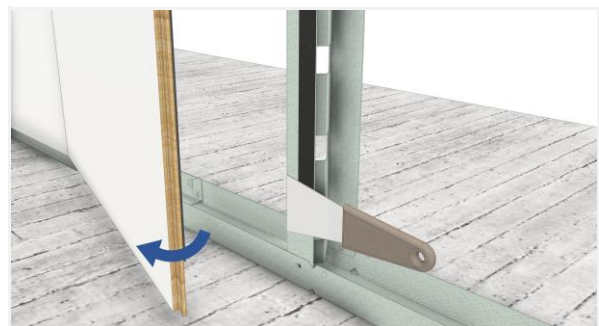

The panel can now be unfolded and clicked loose from the adjacent panel.

## Panel around a door

4.4



Mark the doorway on the back of the click panels. Do the same for each panel adjacent to the door. Saw off any excess. Make sure to leave a small gap between the panel and door frame (see below)



Apply JUUNOO blue tape to the uprights of the door and fold over the backing sheet.



After sawing, thoroughly dust and degrease the back of the panel so that the JUUNOO tape will stick properly to the panel.



Finish the following panels using the same method.

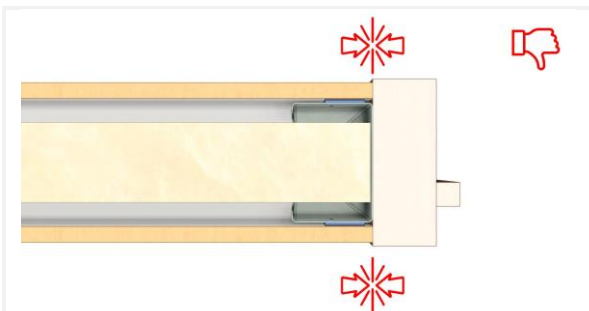

Do not place the panel against the door frame but make sure there is a gap of a few mm.

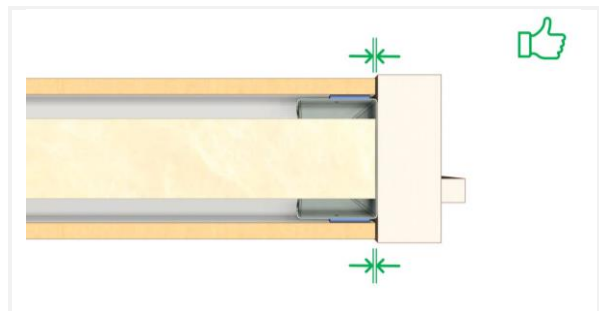

This gap ensures that there will be no acoustic leaks. Moreover, the gap serves as an expansion joint.

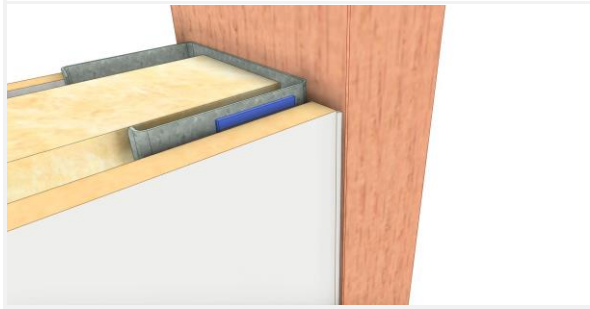

In the case of a block-door, the joint is sealed with sealant.

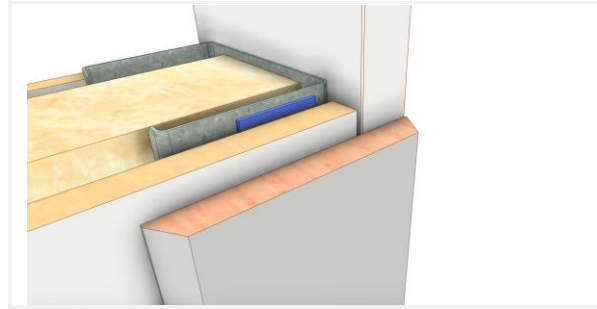

With a painted door, the architrave covers the joint.

### Painting of BaseClick or Acouclick

In addition to a variety of decorative finishes, the BaseClick and AcouClick panels also come in an option that is easy to paint over without the need to pre-treat it.

4.5

It is recommended that an acrylic primer is applied as a first layer and a high-quality solvent paint as the second layer. Brands like Levis and Bosch have a good range of these products.

If the surface of a click panel with a decorative finish has been damaged over the years, it is possible to apply a coat of paint to these panels. To do this, sand the wall gently with a scouring pad and some water with ammonia in it. After cleaning, you should apply a primer and then finish with the appropriate varnish or paint. To achieve the best result, contact the manufacturer for information about the best paint or varnish to use, as well as the ratio of water to ammonia.

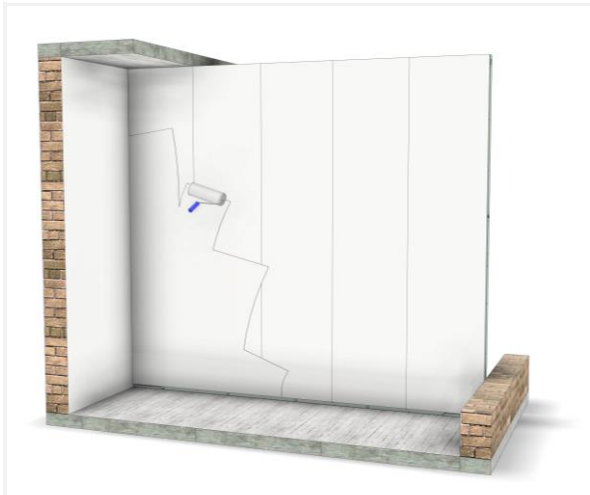

## Textile finish or whiteboard sheets

JUUNOO can be covered with different materials, like textiles or a whiteboard sheet. Panels that can be painted are available for this purpose, or it is also possible to give a new lease of life to old panels where the finish has been damaged over the years.

4.6

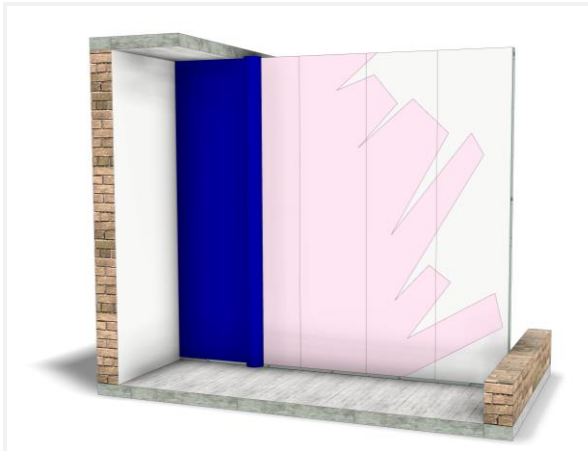

### Textiles.

Ensure the panels are dust-free, apply wallpaper glue, and then smooth the textile over the panels.



### Whiteboard sheets.

Make the panels dust free and laminate the whiteboard sheets over them.

## Drywall panels

Drywall can be perfectly screwed into the JUUNOO modules using black coated self-drilling screws.

By ensuring you use extra strong circular joint sealing strips and the correct filler, the drywall panels can be reused numerous times.

4.7



Put the JUUNOO structure in place. Use modules without JUUNOO tape.



Screw the plasterboards to the structure using self-drilling screws. The drill point ensures that no collar forms around the holes. This increases the reusability of the modules.

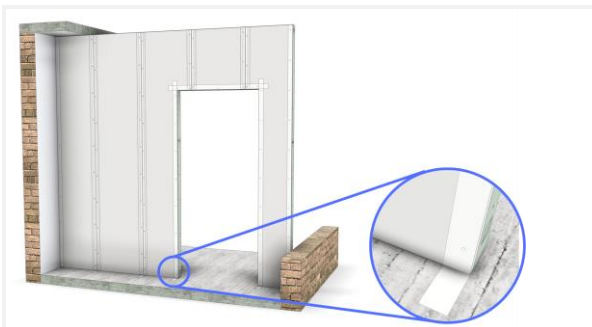

Cover all of the joints and screws with extra strong circular joint sealing strips. Allow  $\pm 10\text{cm}$  to protrude at the bottom. For 120cm panels, the central row of screws should also be covered.

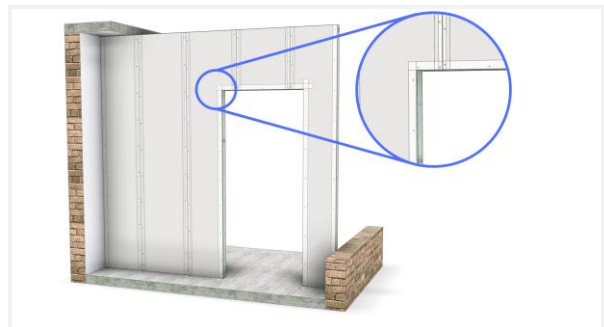

Ensure that intersecting sections of joint sealing strip overlap with each other.

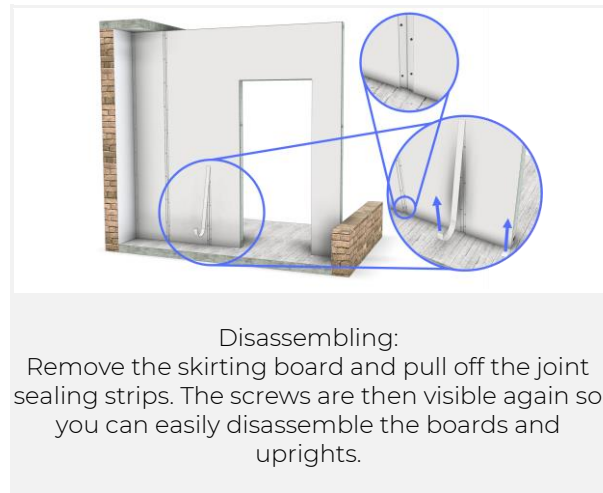
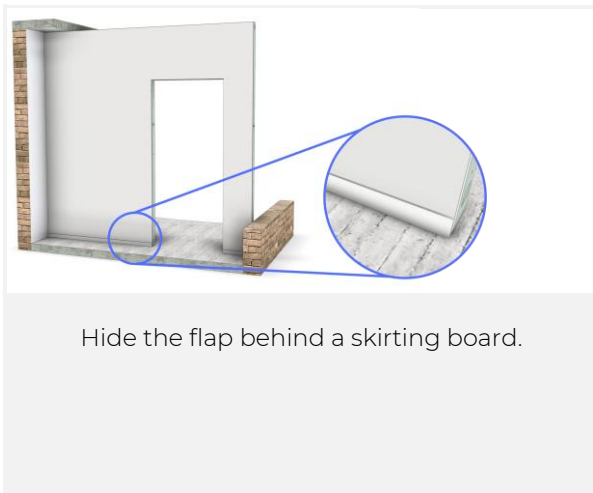
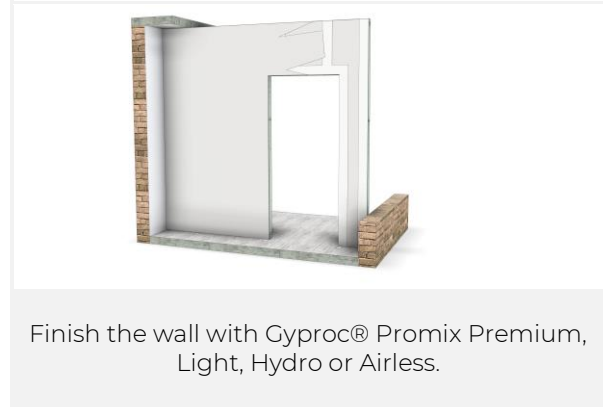
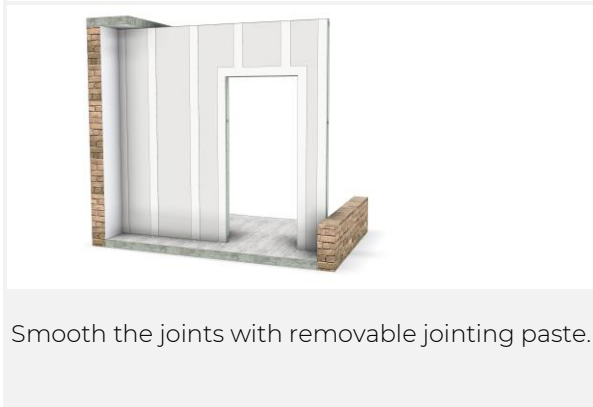

The general guidelines on installing drywall panels and jointing also apply to use on a JUUNOO structure.

When building a gyproc or habito wall, an expansion joint with expansion joint profile must be provided every 15 m.

Ensure the plasterboard and the joint sealing strips are properly centred.

This reusable solution can be used in fire protection and acoustic systems without affecting performance.

## EXTERIOR ANGLE

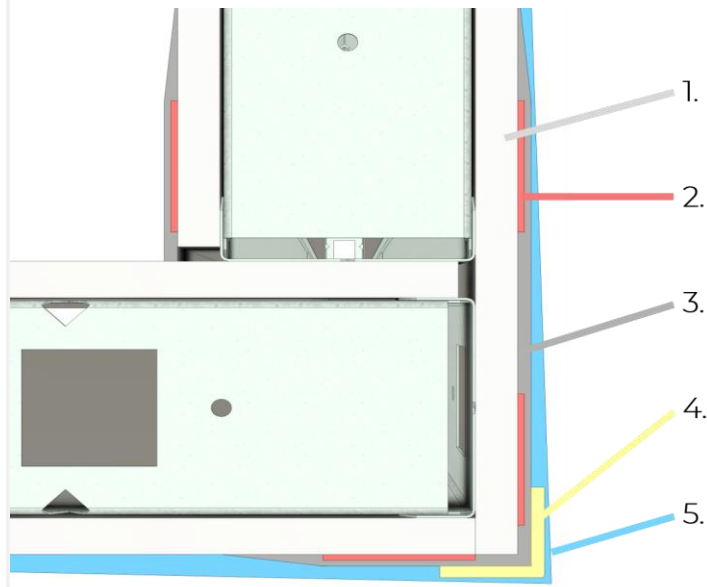

1. Drywall panel
2. Circular joint sealing strips. Leave  $\pm 10$  cm gap at the bottom
3. Circular jointing paste
4. Habito flex 83 (corner profile)
5. Smooth over using circular jointing paste

## INTERIEOR ANGLE

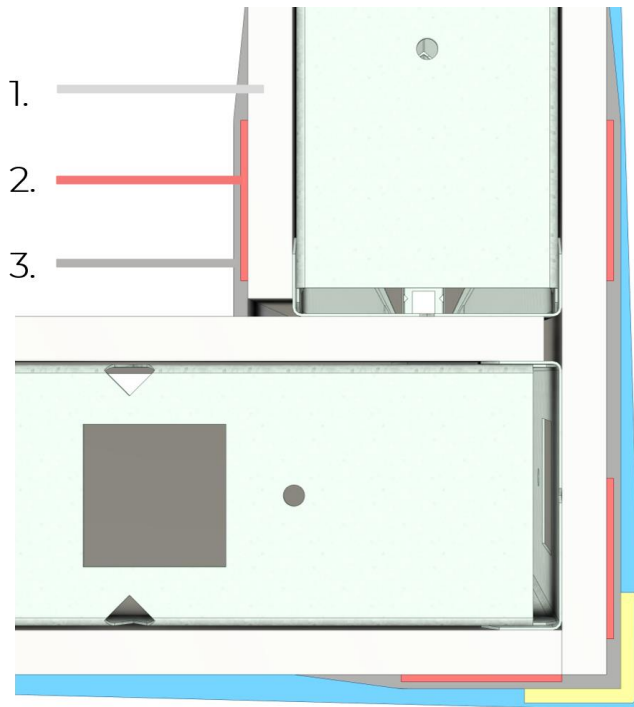

1. Drywall panel
2. Circular joint sealing strips. Leave  $\pm 10$  cm gap at the bottom
3. Circular jointing paste

## OSB and Drywall Combination

4.8

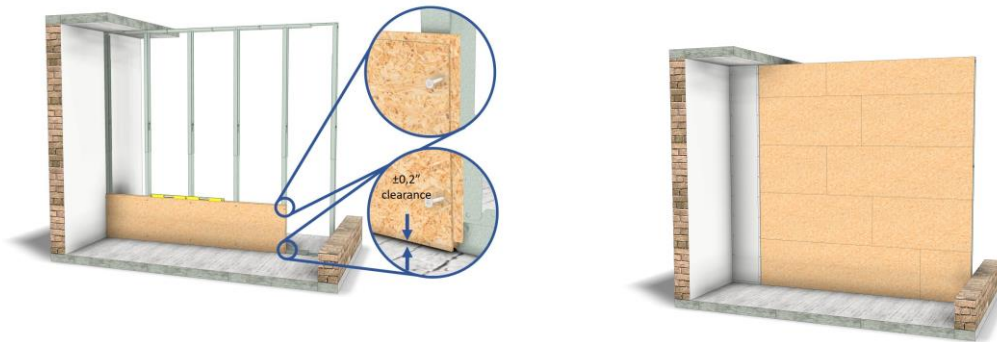

To screw in the modules, use screws with a drill point. This construction is not recommended for long walls. Due to the different expansion coefficients of the wood and the Gyproc, cracks can occur over time. Provide an expansion joint at least every 15m.

## Partition wall panels + click panels

4.9

A thicker chipboard of 12 mm or 18 mm, whether FR or not, provides even higher acoustic performance and increased fire resistance. These can be reused from traditional partition walls. This is finished with click panels. These cannot (yet) be combined with a click panel in 1 structural sandwich construction like the AcouClick. The whole thing is screwed onto the modules.



For modules that do not have JUUNOO blue tape on them, the panels can be fixed using self-drilling screws.

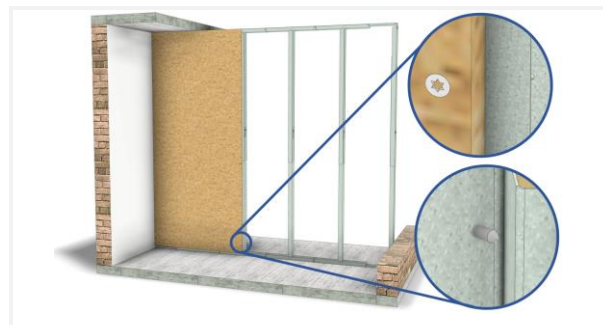

The edge of the panel will be on the centre line of the vertical struts. Note: if you use screws that are too long, they may destroy the interior structure.



Complete the surface with chipboard.

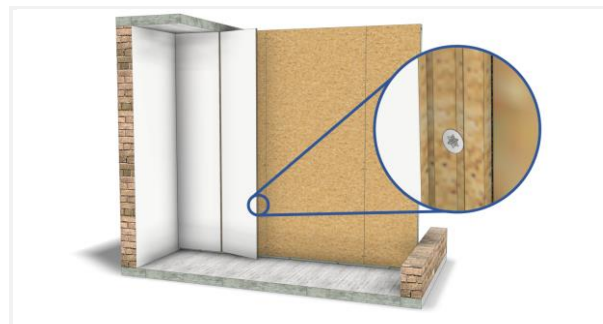

The click panel can be fixed in the groove with small screws and/or with structural adhesive.

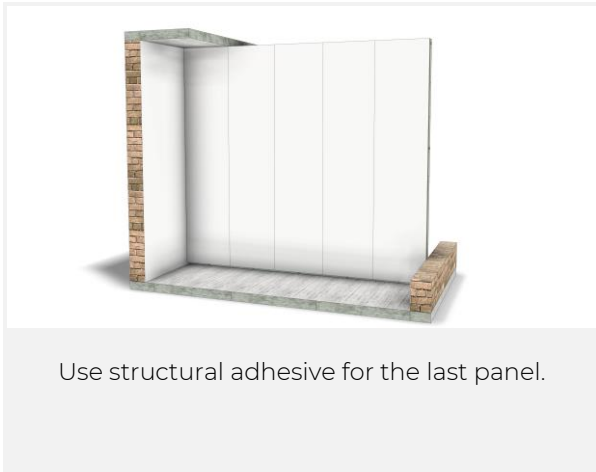

Fixing items to a JUUNOO wall

4.10 A certain amount of weight can be mounted to a JUUNOO wall, e.g. a TV, table, etc. Installation can be done directly on the click panels.

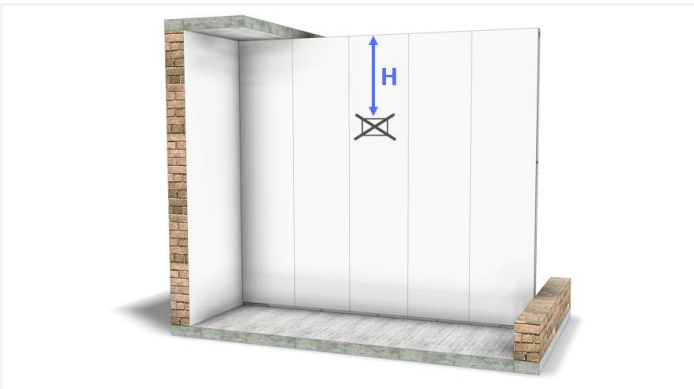

No extra screws if:  
 H = min. 50 cm  
 Weight = max. 5 kg

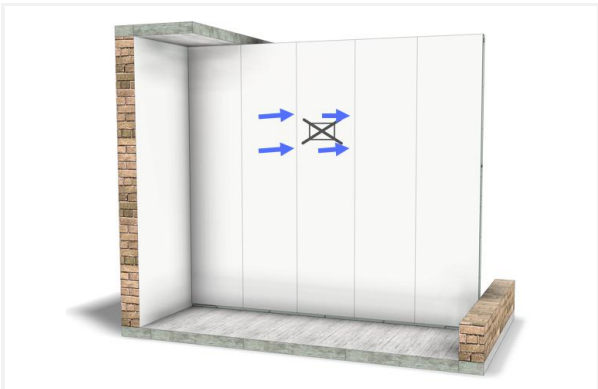

If the height H is smaller than 50 cm or the weight is more than 5 kg, reinforce the panels by screwing them in the modules.



Position the screws so that the object being hung covers them.

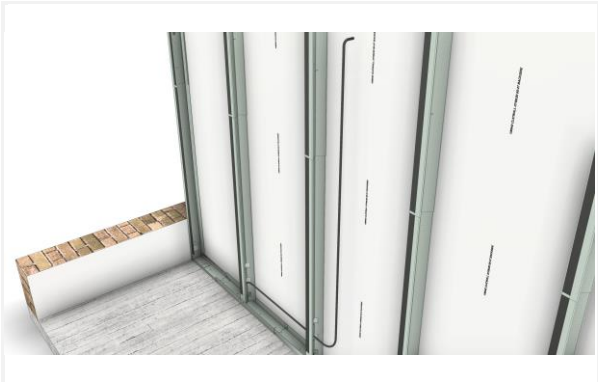

The cables can be integrated into the wall.

### Acclimating the click panels

To avoid deformation before and after installation of the click panels, the following is recommended:

4.11

- Acclimate the panels for at least 48 hours in their unopened packaging in the room where they will be installed. This should be at normal room temperature (15-20°C) and room humidity (50-60%). Keep the temperature and humidity constant during installation. The environment must be wind and watertight in order to control temperature and humidity.
- Do not remove the packaging until installation of the click panels has begun.
- The click panels are not suitable for use in damp and/or humid rooms, extremely dry rooms or rooms that are at extremely high temperatures.
- When cleaning the click panels, avoid using excessive amounts of water.

Temperature and humidity changes can cause click panels to swell or shrink. Allow a 1 mm expansion gap per metre of wall. For walls under 8 m long, leave a gap at the ends and finish it with flexible sealant. Walls over 8 m require additional expansion gaps.

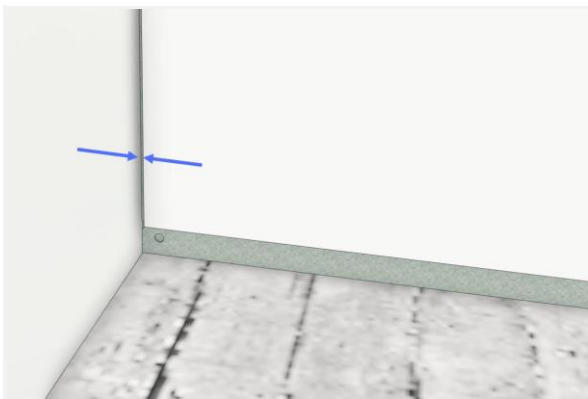

Walls shorter than 8 m:  
Expansion joints can be provided at the outer ends of the wall.  
Calculate 1mm per meter of wall.  
Finish with sealant and/or with an alu-profile.

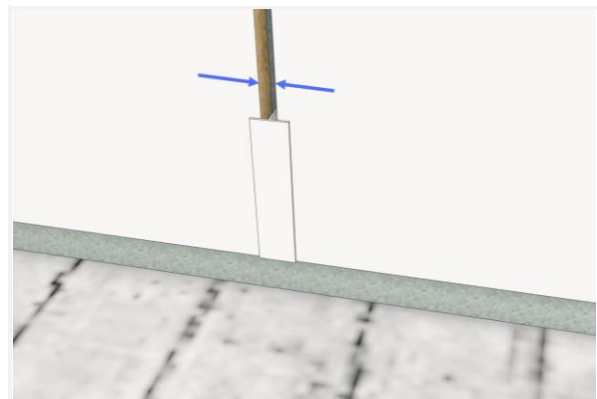

Walls 8 m or longer:  
An extra expansion joint is required.  
This can be finished with sealant combined with a small T-profile.

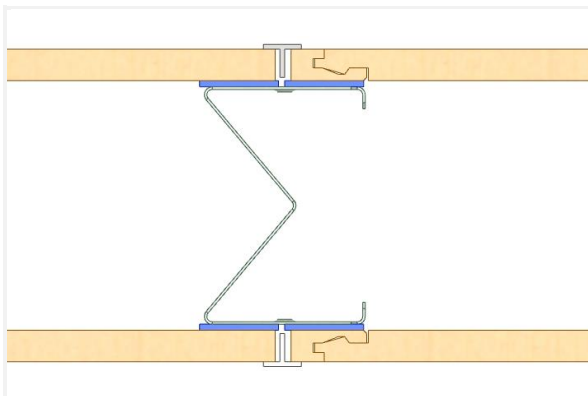

The expansion joint of 5 mm is located on the I modules. Extra JUUNOO tape is added for support. With flexible silicon on the entire length of the seam a T profile ( $\pm 12 \times 10$  mm) is glued.

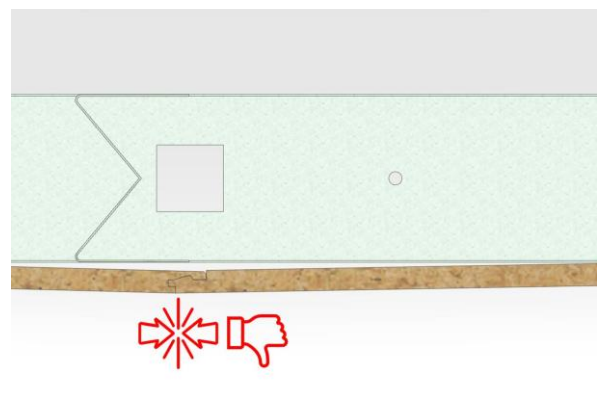

Without an expansion joint, there is a chance that panels will come loose and thus form irregularities in the wall.

## 5 Finishes

### Outer corners

#### 5.1.1 Corner profile BaseClick en AcouClick

Outer corners are finished with an aluminium outer corner profile with a visible 10x10mm side.

5.1 The profiles are delivered in white, black or anodised.

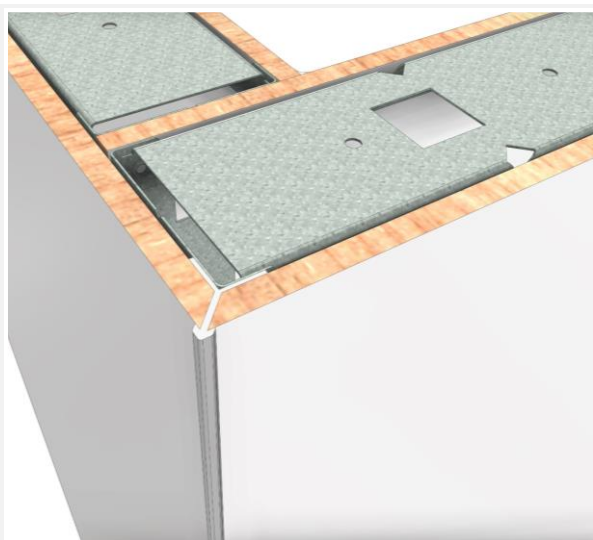

The wall with Baseclick has a corner profile with 'legs'. This profile is glued onto the panel.

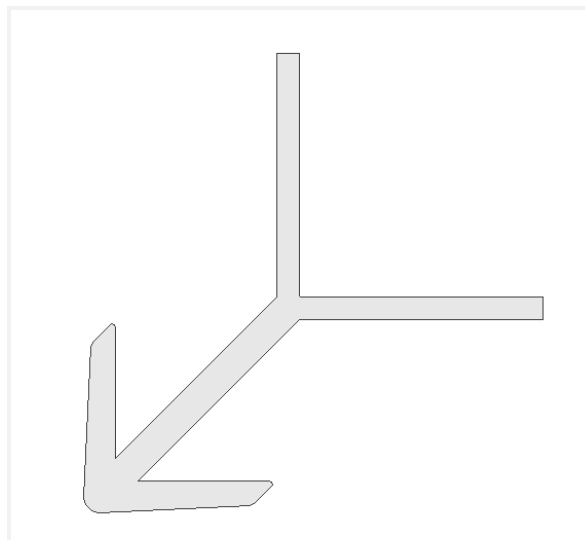

Corner profile for Baseclick

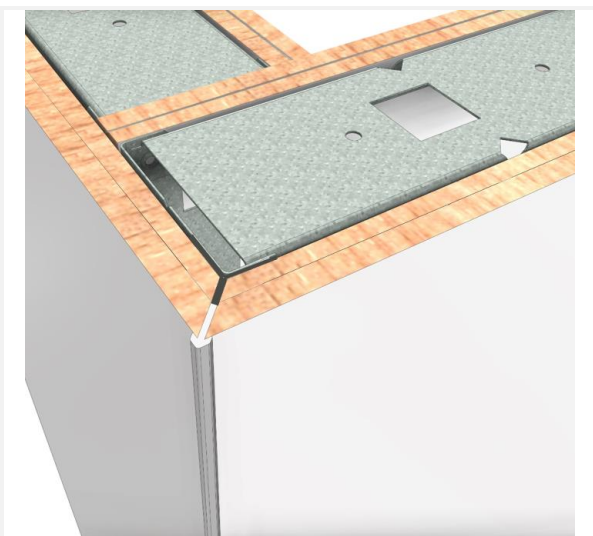

The wall with AcouClick has a corner profile without 'legs'. This profile is glued onto the panel.

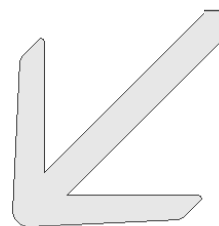

Corner profile for AcouClick

## 5.1.2 Mounting of aluminium corner profile 90°



Saw a panel at 45°.



Apply JUUNOO tape (hook), pull the backing paper off, and degrease the panel on the back.



Apply sealant to the 'legs' of the corner profile, where there is contact with the panel. The profile does not need to be glued to the C-module.



Slide the profile over the panel.



Fold the panel. Slide the profile leg between the already mounted panel and the C-module.



To allow it all to dry, clamp the 2 panels together using masking tape.

### 5.1.3 Corner > 90°

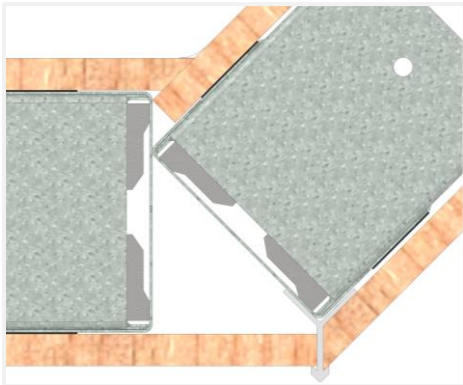

The construction of this corner is like a 90° angle.

### 5.1.4 Corner < 90°

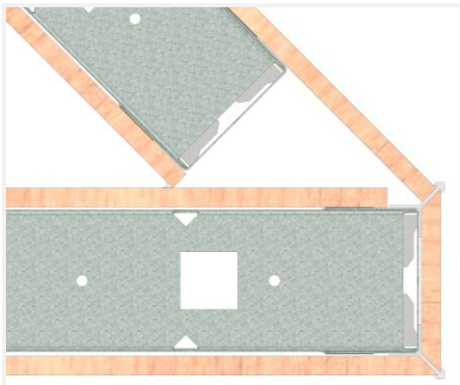

The construction of this corner is the combination of a 90° angle and a >90° angle. So, the effect is similar to both.

### Inner corners

Sealing the inside corner is a quick and inexpensive method that gives the best acoustic result. Afterwards, the panels can still be dismantled, and the sealant can be scraped off the panels using a scraper and a scouring pad for the last residues.

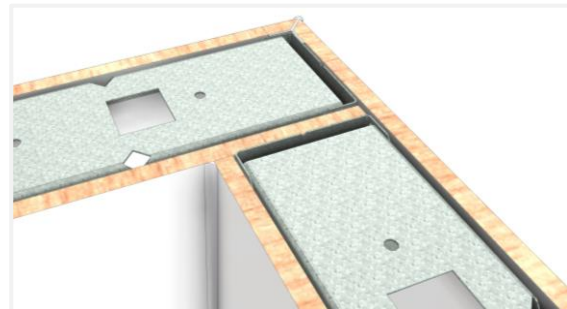
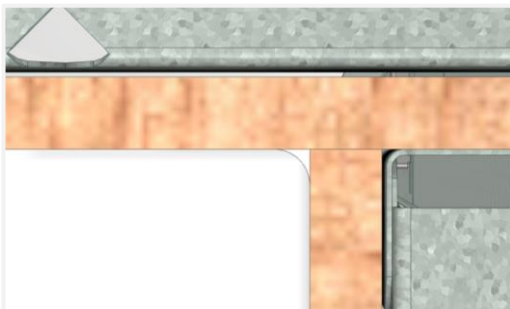

## Acoustic decoupling of a wall

To meet technical fire and acoustic requirements, it is important to decouple the JUUNOO modules from the floor and ceiling. Furthermore, the perimeter of the wall must be sealed (including the top and bottom of the skirting board). A 3 x 30 mm PE foam tape is needed to ensure decoupling.

- 5.3 The modules should be fixed at the top and bottom, in the horizontal U-profiles, every 600mm with a screw or nail plug (6mm > Ø > 4mm). They should be ideally fixed in the openings provided by JUUNOO, as close to the upright struts as possible.

For vertical connections, they must be fixed every 750mm.

The connection between the finishing panels and the floor must be carried out according to the instructions provided by the manufacturer of the finishing boards.

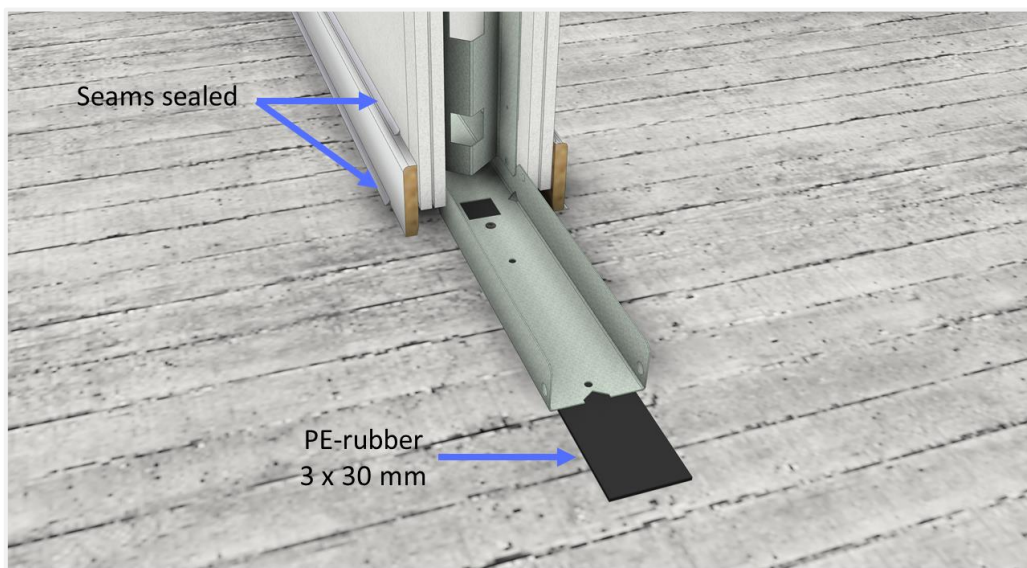

## Floor connection

### 5.4.1 Skirting boards

Skirting boards are fixed to the JUUNOO wall by means of JUUNOO Glue. This double-sided tape has a very high adhesion from the start, hardly degrades over time and leaves no damage or glue residues when removed.

5.4 In this way, the panels and the skirting board are perfectly reusable.

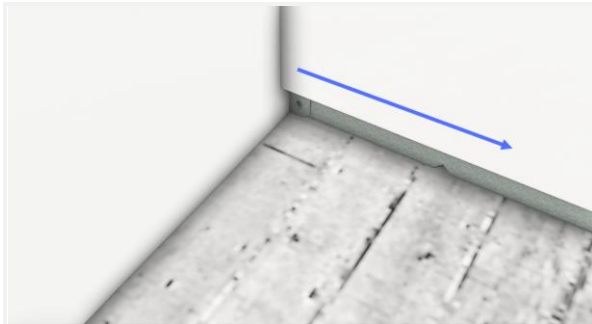

Make sure the underside of the wall is dust-free.



The JUUNOO Glue is already applied to the skirting board. Textile tabs are included.

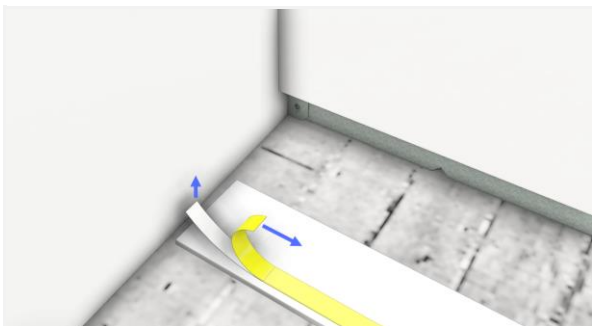

Detach the cover sheet and the first few centimeters of the tape.



Insert a section of the textile tab under the tape. Make sure that the tab on the other side of the tape sticks out a little.

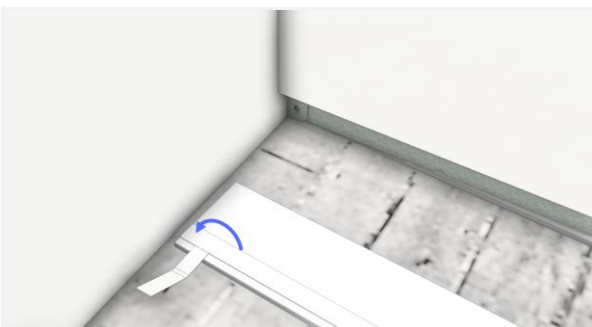

Stick the loosened tape over the tab again.

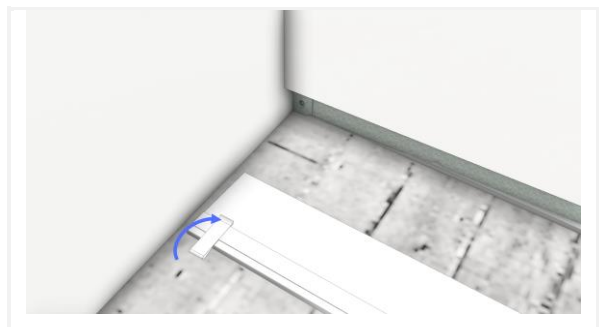

Fold the tab in half over the tape to create a small loop protruding from the skirting board.

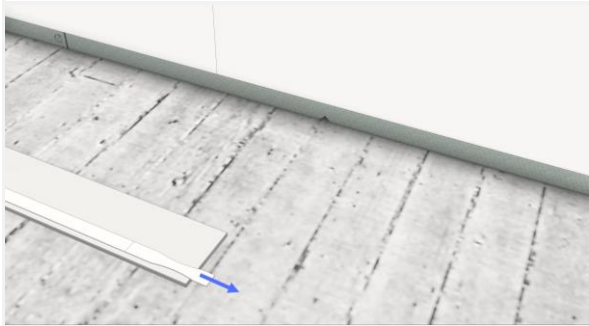

On the other side of the skirting board, stretch a small piece of the tape and reattach it.

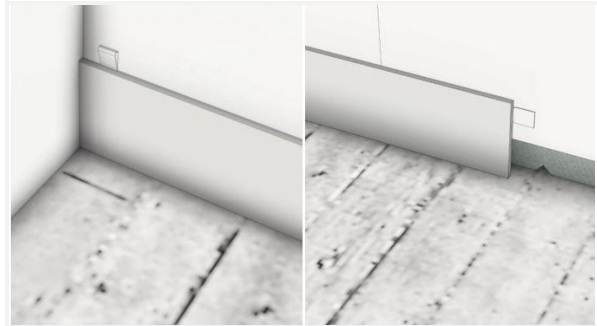

Stick the skirting board to the wall and press firmly.



For the next skirting board, also provide a piece of stretched tape at the end. Attach this skirting board over the protruding piece of tape from the previous skirting board.



Continue building by connecting each skirting board with the previous one. A new textile tab must be used each time a new set of skirting boards is installed.

### Removing the skirting board

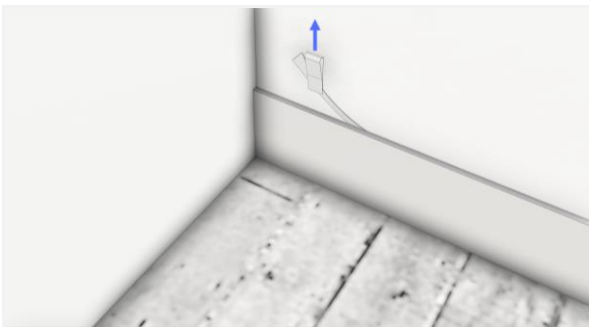

By pulling the textile tab, the tape is stretched and loses its adhesive power. In this way the JUUNOO Glue is pulled from between the skirting board and the wall panel.



The overlap of the tape between 2 skirting boards ensures that all skirting boards can be removed in one series. There is no damage or glue residue to skirting boards or panels.

Tip:

Instead of a visible textile tab, a piece of JUUNOO Glue can also be hidden behind a door frame or in a corner.

Here you do run the risk that the ends of the tape are not easily found when dismantling.

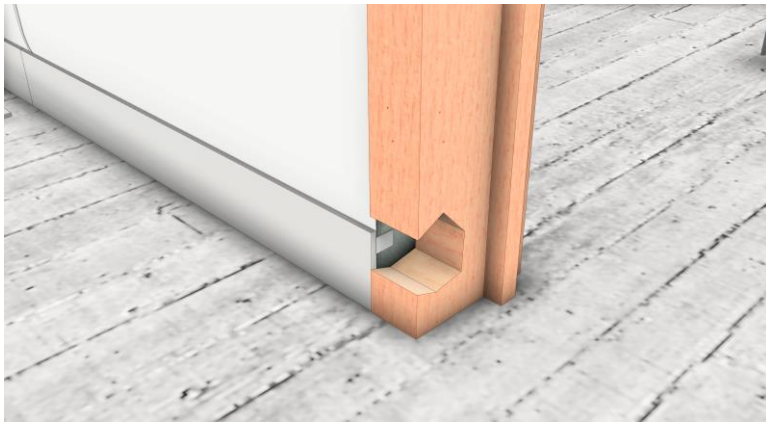

Another possibility is not to provide a textile tab. Then the skirting board of the first/last panel has to be wrenched off in order to reach a piece of JUUNOO Glue. Then the first or last panel is damaged.

### Edge finishing

5.5 If a wall has a free end, the end of this wall must be finished. Depending on visual preference, different finishes are possible.

#### 5.5.1 Finishing with aluminium profile



Apply a BaseClick panel on both sides.

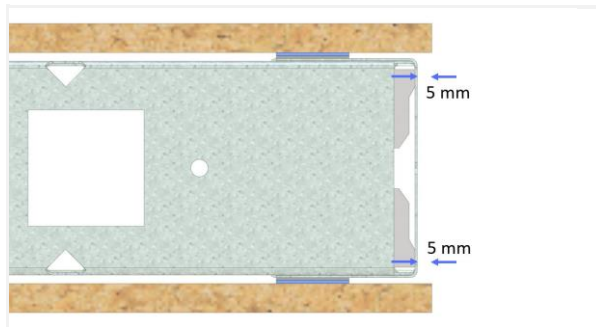

The panels should extend  $\pm 5$  mm beyond the C-module.

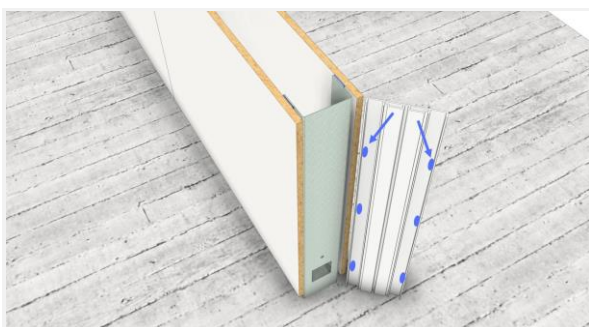

Apply small dabs of silicone adhesive to the inside corners of the cover profile.

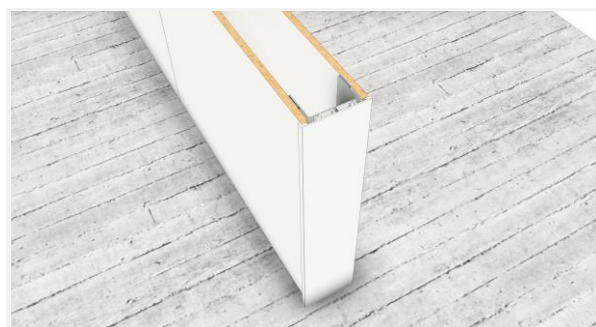

Position the profile and press.

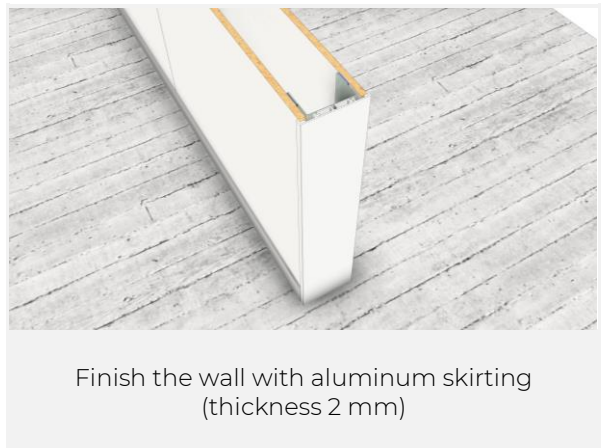
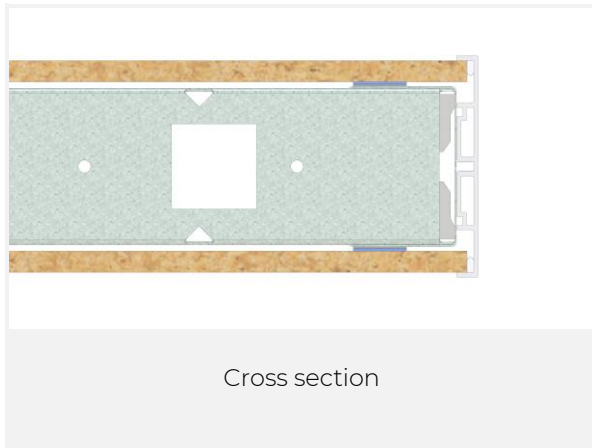

### 5.5.2 Finishing with click panels

The advantage of this construction method is that the décor at the end is the same as the décor on the wall. The construction of this is like the construction of a corner with a click panel.

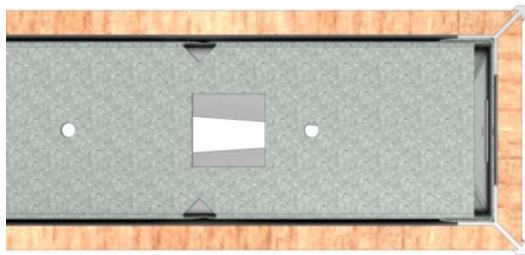

## Ceiling and wall connection

### 5.6.1 Sealing

Sealing the top joint is the most commonly used finish today. The benefits in terms of speed and acoustic qualities are usually the deciding factors.

The prerequisite for this to work is that the ceiling is relatively flat so that the gap between the panels and the ceiling is not too large when the ceiling goes up.

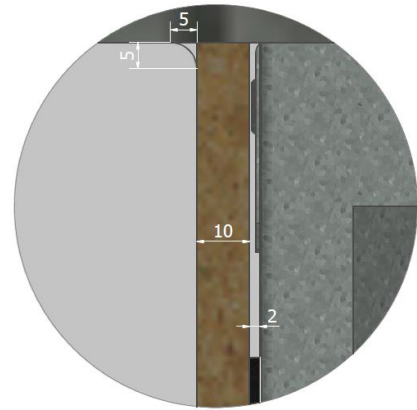

### 5.6.2 Aluminium corner profile

In addition to an internal corner profile between 2 walls, a corner profile can also be used as a finish against a drop ceiling. A profile works better because caulking will leave uncleanable residues on the types of ceilings. For this to work properly, the profile must extend between the ceiling and the panels, and the ceiling needs to be flat.

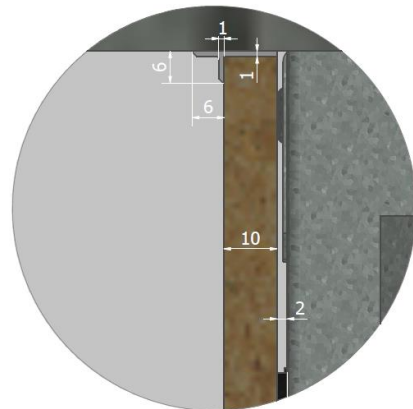
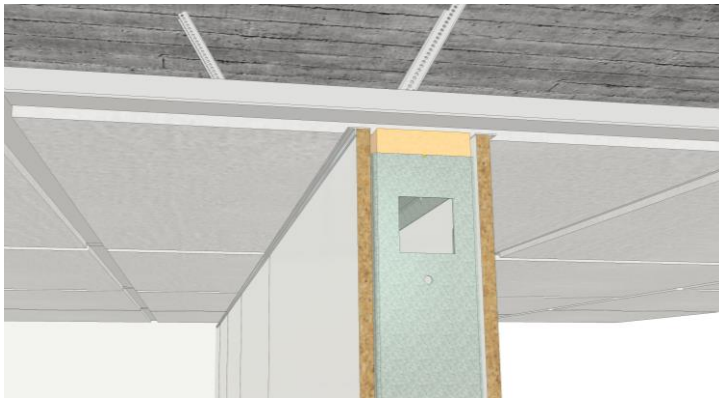

### 5.6.3 Shadow gap

A shadow gap is used for decorative effect or when the ceiling must not be glued. EPDM rubber is applied to the modules before the panels are put against them.

A shadow gap of 5 mm looks very visually appealing, but for this to work properly, the ceiling needs to be very even so that the gap is the same width over the entire length.



A shadow gap of **20 mm** gives more leeway for uneven ceilings or false ceilings, for example.



5.7

## Connection to an existing building

### 5.7.1 Finishing on an existing skirting board



Place the C-module against the skirting board.

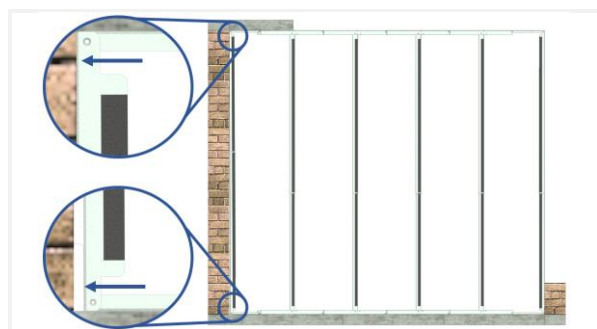

Fix the top and bottom of the C-module as closely as possible to the wall.  
*Note: the C-module may be angled slightly, just as long as the first I-module starts out level.*



Make a cut-out in the click panel for the skirting board.



Let the click panel fit fully against the wall.

For acoustic reasons or if JUUNOO tapes are used, it is best if the C-module completely fits against the wall. Other possibilities for attaching the C-module to the wall are below.



Make a recess in the skirting board the width of the wall.



The wall fits into the recess.

## 5.7.2 Finishing around a recess

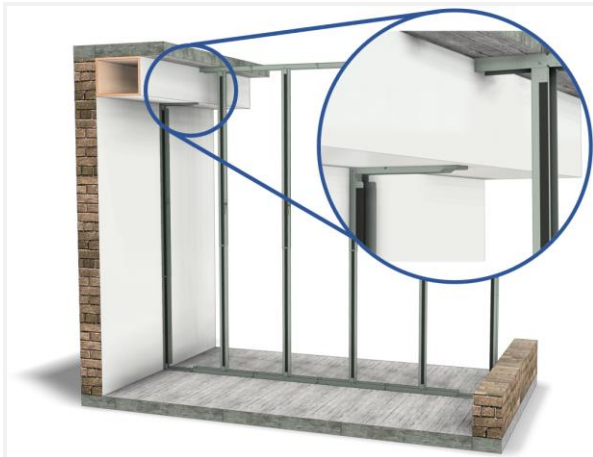

Fix the C-module under the recess. Ensure the I-module is level. You may need to cut a piece of this.



Fix the C-module bearing, cut I-module if necessary.

### 5.7.3 Finishing around pipes

Ideally, ventilation pipes etc. should be installed after the wall is in place. Then, you will only need to make a hole in the wall and insert the pipe through it. It goes without saying that this makes the finishing process nice and easy. However, it may be the case that there are already pipes in place. Follow the method below as an example of how this can be dealt with.



Insert all modules. In most cases, piping comes between the studs and you can attach the horizontal profiles above the pipes to the ceiling.

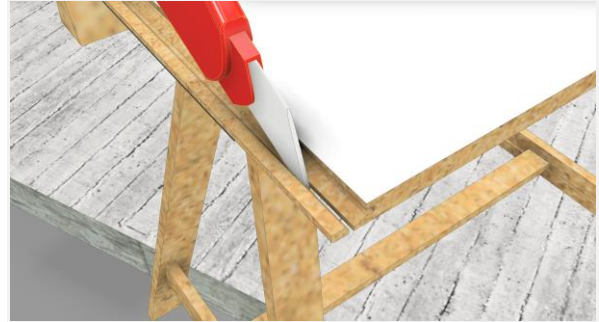

After installing the first click panel, cut off a piece of the groove of the 2<sup>nd</sup> panel.



A piece of the JUUNOO tapes is also cut off.



This panel is attached to the first panel in the normal way.

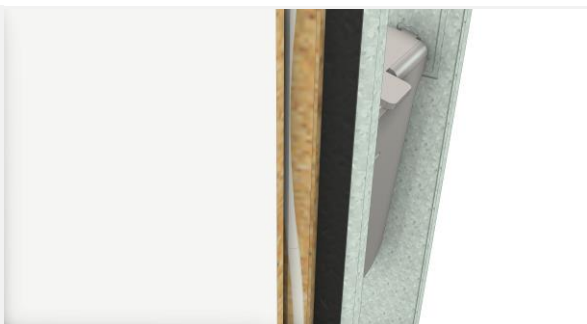

Apply a fine line of transparent silicone glue in the groove.



From the 3<sup>rd</sup> panel, make a cut-out for the pipe with a tolerance of 3 mm. Apply it from below, but do not press it against the tape of the I-module yet.



Without the pipe, the panel could rotate to snap into the 2<sup>nd</sup> panel. The pipe prevents this movement.

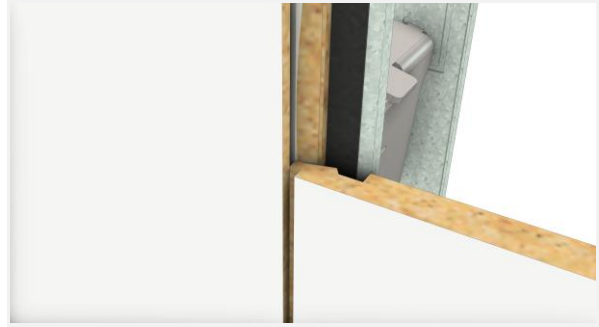

The cut groove allows the tongue of the 3<sup>rd</sup> panel to slide sideways into the 2<sup>nd</sup> panel. This requires a 3 mm clearance around the pipe itself.



The silicone glue holds the connection in place.



Put in place the top piece of the panel.



Slide the panel into the groove of the left panel before pressing down on the tape.

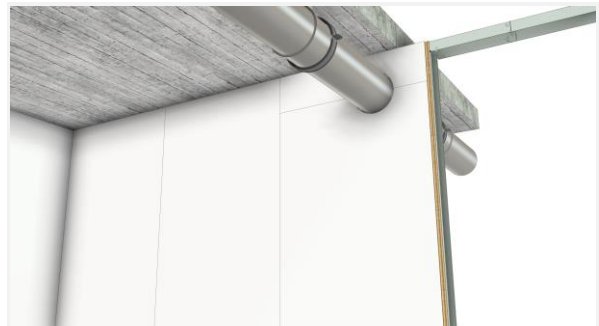

Construction can then continue as usual.

If the profile of the I-module cannot be inserted above the pipe, a piece of the profile can be cut off.

#### 5.7.4 Pipes ending on struts

If the strut of the I-module ends in a pipe, it is not usually possible to fix the module to the pipe.



Position timber under the pipes and between the I-modules on the left and right of the central module.

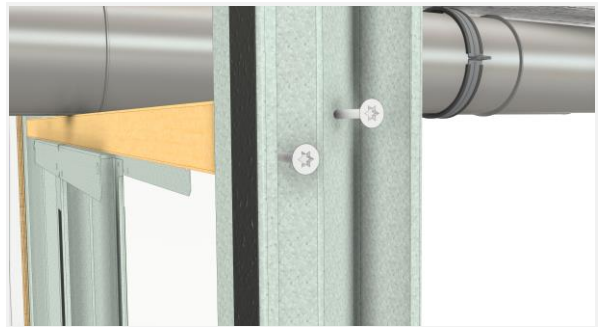

Fix the timber with self-drilling screws.



As described above, cut a strip from the groove of the first panel. Apply transparent silicone glue in the groove.



Make a cut-out in the panel. Again, cut a strip off the tongue. Apply it as described above. Finally, slide the panel to the left to lock in place.



Follow the same procedure for the next panel.



Slide to the left to fix. Continue building.

## Connection to the window

5.8



Fix the C-module as close to the window as possible.



Fix a wooden bar to the window to support the click-in panel. Apply JUUNOO tape to the C-module.

*Tip:* if the window is deep enough, a small C-module can also be used.

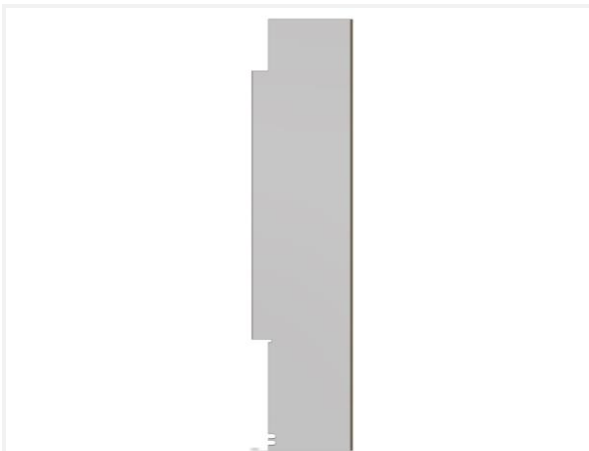

Cut the contour of the windowsill and pipes out of the panel, measured from the first I-module.



Be sure that everything is in the right place properly before pulling off the backing sheet from the tape.

*Tip:* before pulling the backing sheet from the JUUNOO tape, fit the panel to the contour

## 6 Doors

### Installation of a standard, unpainted door

6.1



Position and fix the I-modules and the 120 cm door profile.



Place the C-modules in the doorway, but do not fix them yet.



Assemble the frame with the screws provided.



Place the frame between the C-modules and slide the C-modules against the frame.

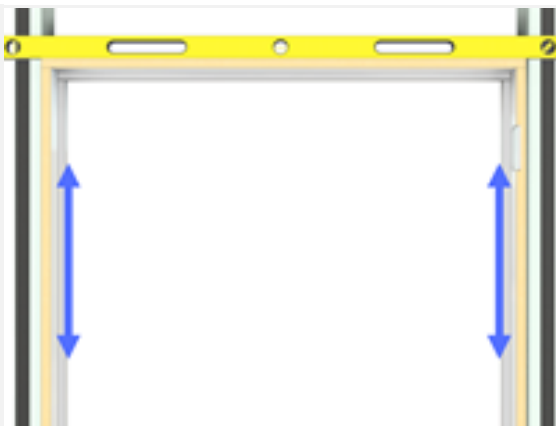

Level the top slat and fix both C-modules to the frame.

*A more detailed explanation of the installation is described below.*



Hang the door leaf.  
Level the C-module on the hinge side.

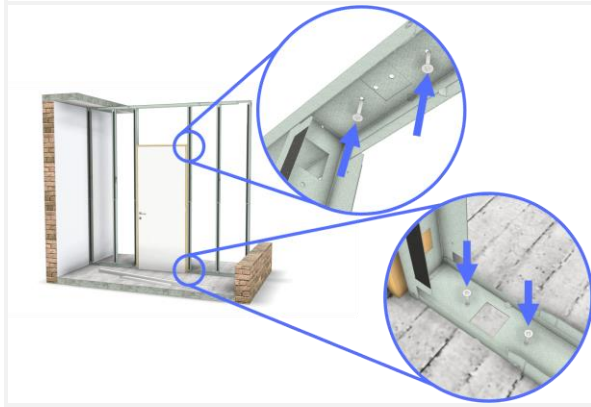

Fix the C-module at the bottom and the top.

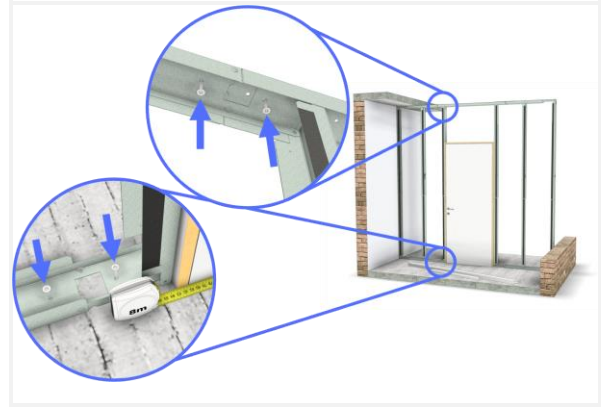

Align the C-module and frame on the strike side of the door with the door leaf. Fix this C-module in place.



Place the header on the frame and slide it open. No need to screw it on.



Attach the click panels to the modules.

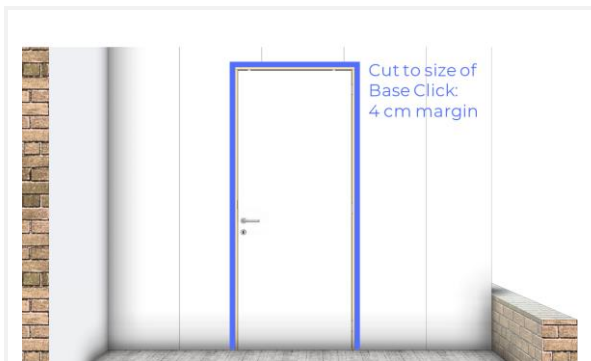

If the door frame has an architrave, the click panels do not have to be perfectly aligned with the frame. A margin of 4 cm is possible. In any case, ensure that the panels do not touch the door frame so that acoustic leak is avoided.



The architraves are prefabricated and cut to size. Attach them to the frame.

## Levelling a door

When installing a door, it is important to pay attention as to whether the floor slopes. This can cause the door to drag or leave an unsightly gap between the door leaf and frame. By using JUUNOO modules, the door frame can easily be levelled to avoid these problems. Below are some additional steps to align the door frame perfectly in a horizontal orientation.

6.2

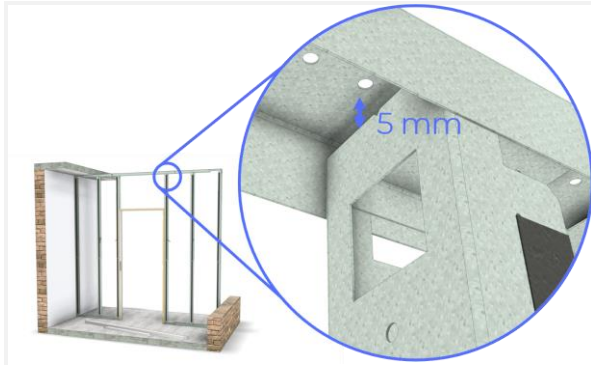

When fitting the C-modules: leave  $\pm 5$  mm clearance between C-modules and door profile. Leave the Quickspans open.

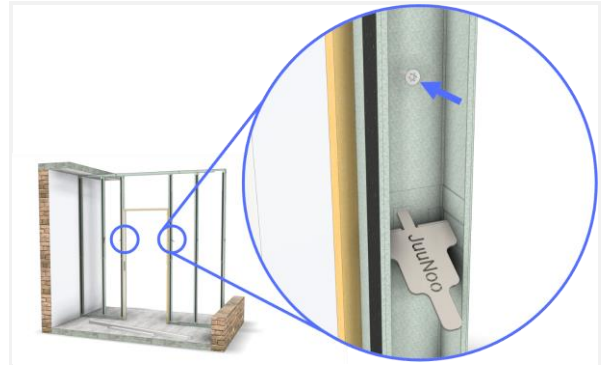

First screw the top vertical profiles of both C-modules to the frame.

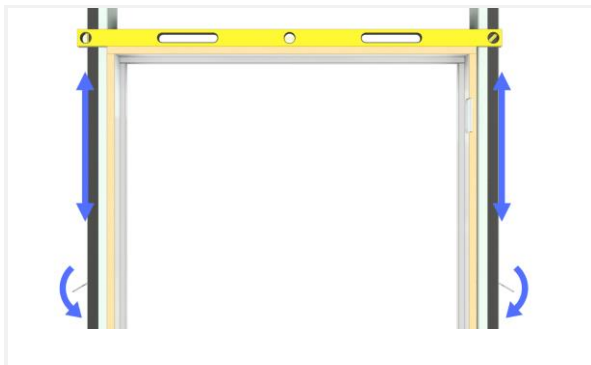

Level the top side of the frame. Raise the side that is hanging lower by gradually tightening the Quickspan.

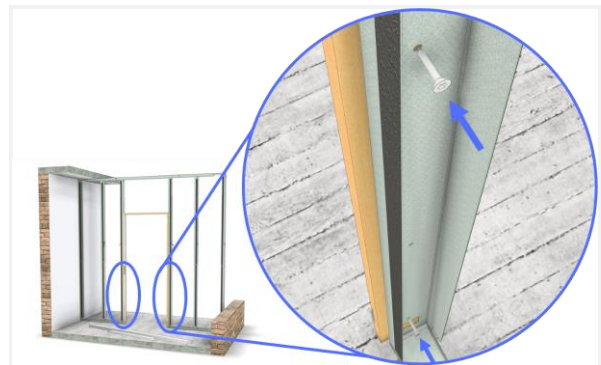

Screw the frame on the bottom against both C-modules. If necessary, fold down the Quickspans completely.



Hang the door leaf in the door frame.



Level the bottom of the C-module on the hinge side and fix the base.

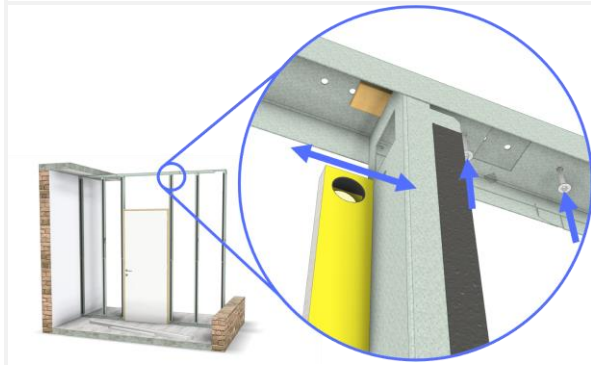

Level and fix the top of this C-module. Put a wooden block between the C-module and the door profile if there is too much play.

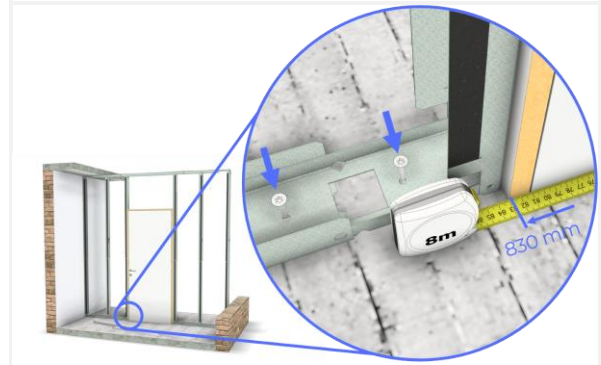

Set the bottom edge of the door frame to the correct width. Fix the base of the C-module.

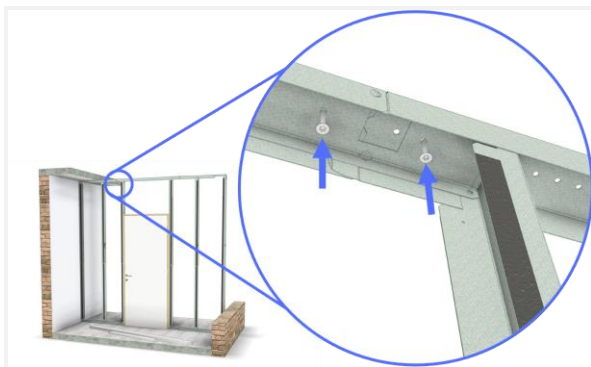

Finally, fix the C-module to the door strike side. Put a wooden block in between if necessary.



Finish the wall with the header, architrave and click panels.

## 7 Glazing

### General principle



The JUUNOO Glass can be reused cost-effectively if we standardize the glass. The remaining height and width of the wall are completed with the JUUNOO modules and panels.

If still required, the glass can also be supplied to measure.

Standard glass pane size: 900 x 2335 mm (for opening height 2360 mm)

Weight of a standard glass pane: 68,3 kg for 66.2(A) glass / 83,3 kg for 88.2(A) glass

### 7.2 Installation

Tools required:

- Drill and screwdriver
- Metal drill bits (3mm) and possibly stone bits
- Crosscut saw for aluminum
- Laser
- Glazing paddle (for loosening the snap-in profiles)
- Rubber hammer
- Glass carrier
- Seaming tools
- Setting blocks in different thicknesses
- Cleaning agent for glass + some clean fiber cloths
- Meter
- Box cutter

## 7.2.1 Glazed wall

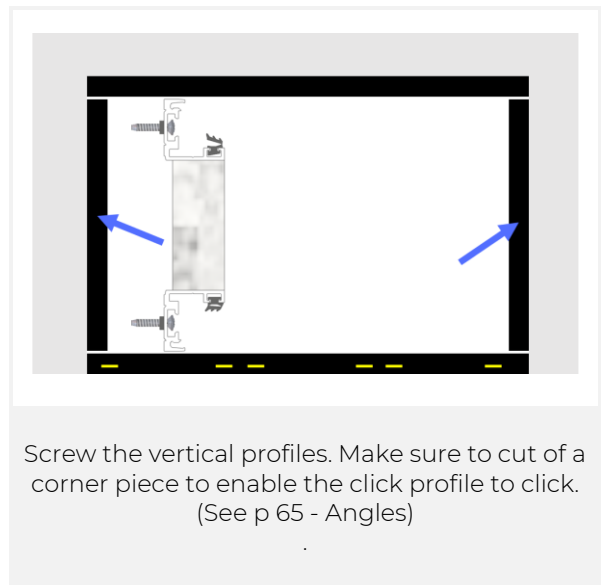
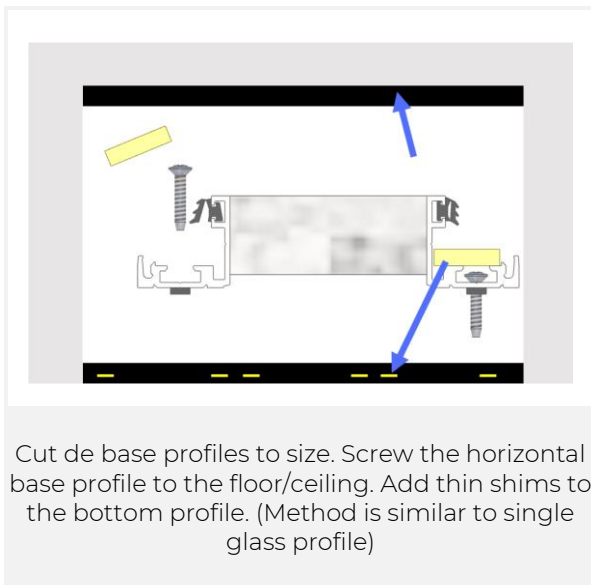
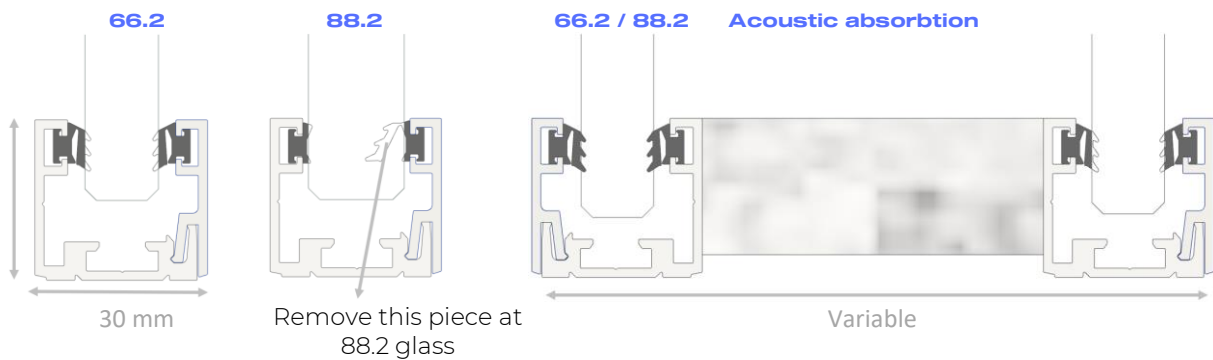

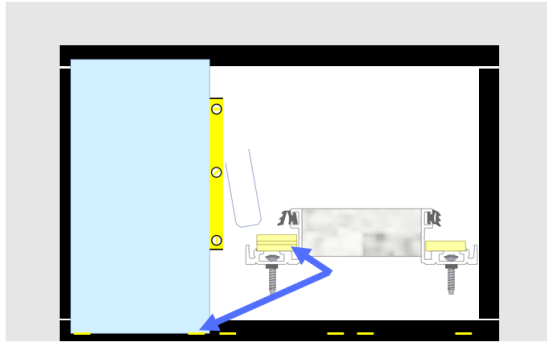

Place the first glass sheet. If necessary, add extra shims under the glass until the glass sheet is level.

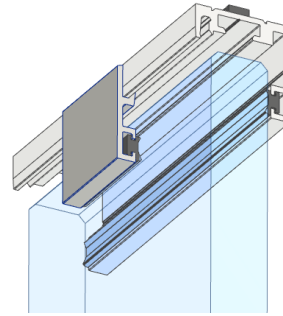

Tip: the glass panes can be temporarily secured during installation using a short piece of click profile.



Remove dust and grease from the glass edge. Apply the G2G (Glass to Glass). Press firmly.

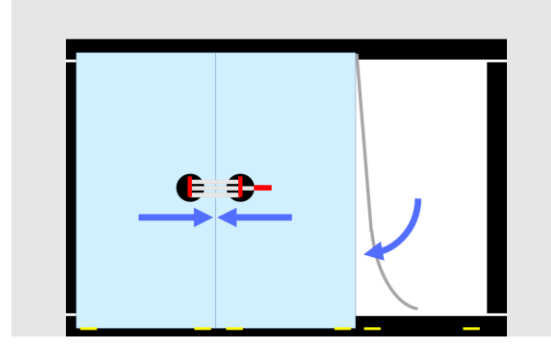

Place the second glass sheet. Add shims to make it level. Stick it firmly to the first glass sheet using glass tensioners. Add a G2G.

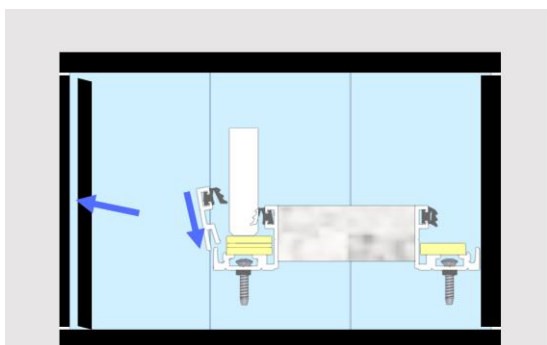

Cut the click profiles to size. Fix the glass with these. It helps to push against the glass while hammering the profile with a rubber hammer.



Clear the glass on the inside and vacuum the acoustic felt. Place the second layer of glass like the first layer.

Instead of screwing into the floor, JUUNOO Glue can also be used. This is only possible on a flat and clean surface. Impact tests have been performed on these parts (see reverse of this bundle). The vertical glass profiles can also be attached using the tape. Horizontal glass profile at the top *must* be screwed in. When using the JUUNOO Glue, no PE sealing rubber is used.

### Disassembling a glass wall

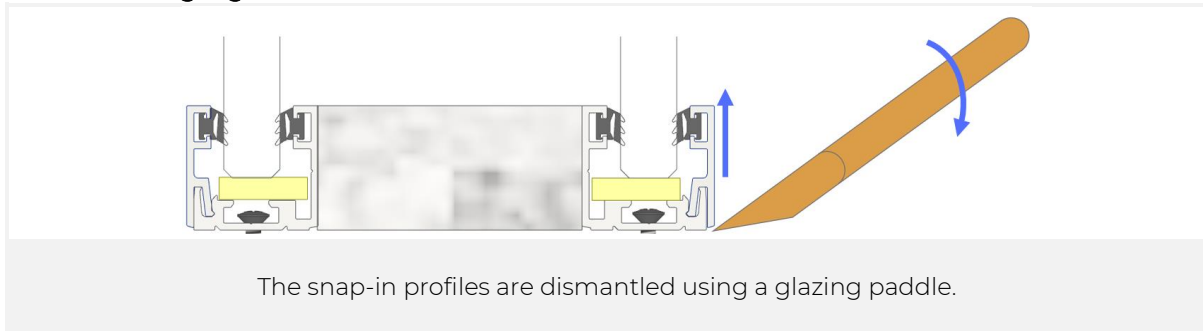

## 7.2.2 Corners

To create an upright angle with the glass profiles, proceed as follows:

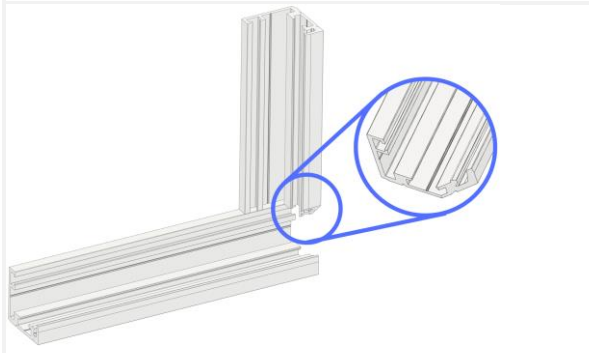
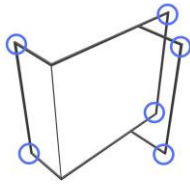

First, install the horizontal profile.  
Cut the vertical base profile at an angle.  
Then install it.



This corner ensures that the horizontal snap-in profile does not knock against the vertical base profile.



Install the snap-in profile onto the horizontal base profile.  
A click can be heard when it is secured.

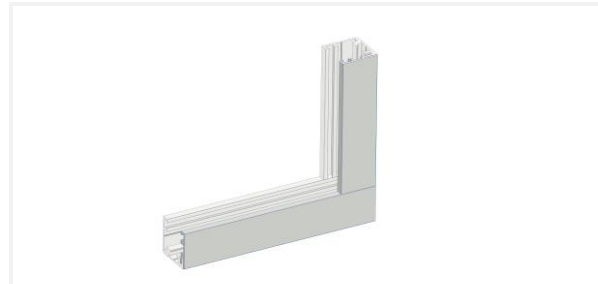

Saw the vertical snap-in profile to size and click it into place.

A horizontal angle is made in the manner below. If the snap-in profile is on the inside of the corner, the method is the same.

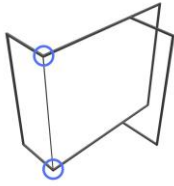

Cut and fix the base profiles at a 45° miter (or other desired angle).  
Measure the snap-in profile to be cut and use a leftover snap-in profile to identify the exact over measurement.



Cut the snap-in profiles to the correct angle and click in place.

To create a T-joint proceed as follows:

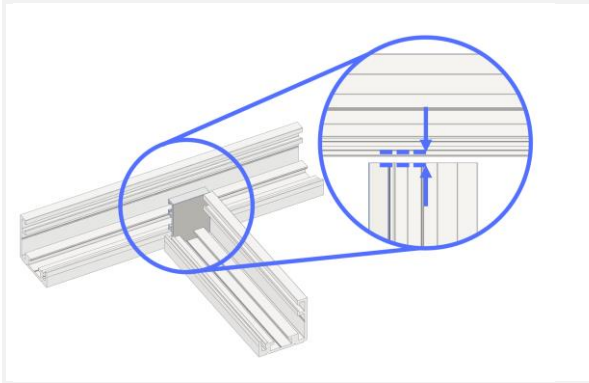
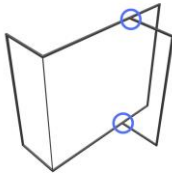

Install the base profiles. Make sure a snap-in profile fits between the connection of the angled profile.

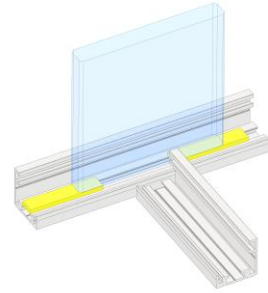

Install the glass in the continuous profile.

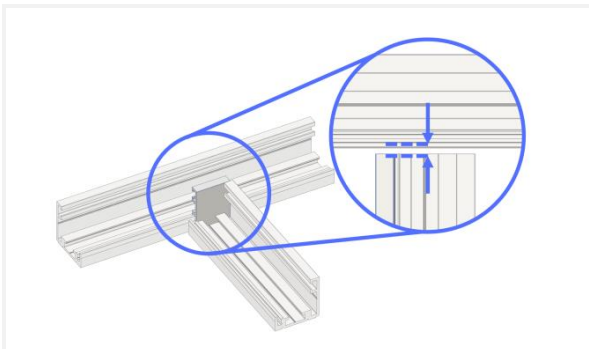

Cut the snap-in profiles so they align with the inside aluminum of the angled base and snap-in profile.

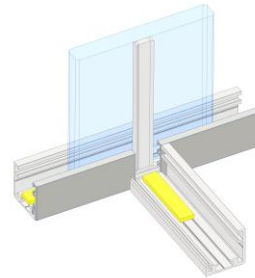

Apply the G2G to the glass using a laser and press firmly. Place min. 3 mm setting blocks in the base profile.

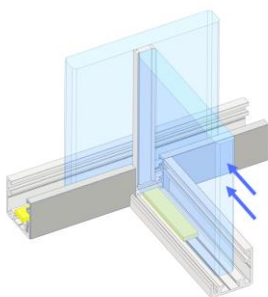

Insert the glass and press it very firmly against the G2G.

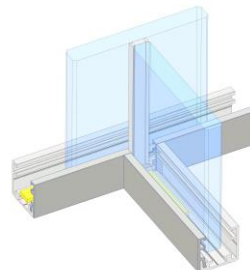

Click the glass in place.

For a T-joint with double glazing, the principle remains the same. At the level of the acoustic absorption, a piece of snap-in profile is placed in between.

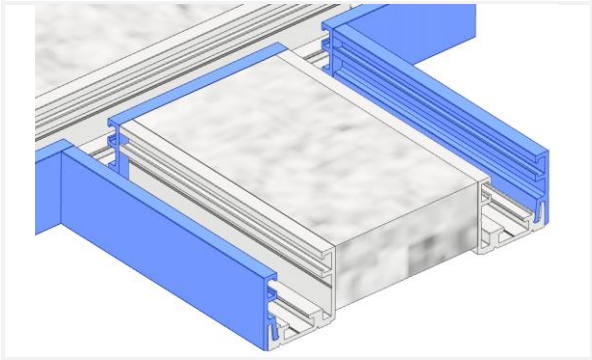
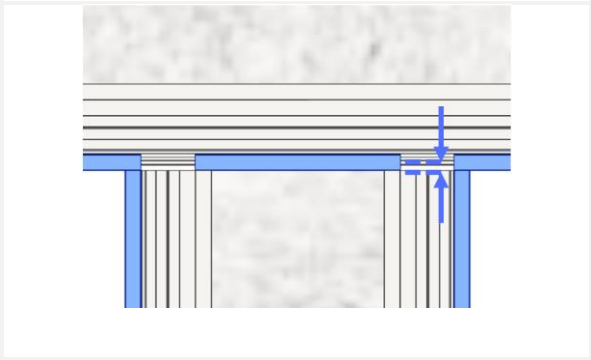
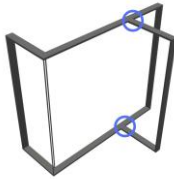

7.2.3 Connection of glass wall to a JUUNOO wall

*SINGLE GLAZED WALL*

The end of a wall clad with BaseClick is finished with an aluminium U-profile. Against this, all kinds of things can be mounted, among which single glass profiles.

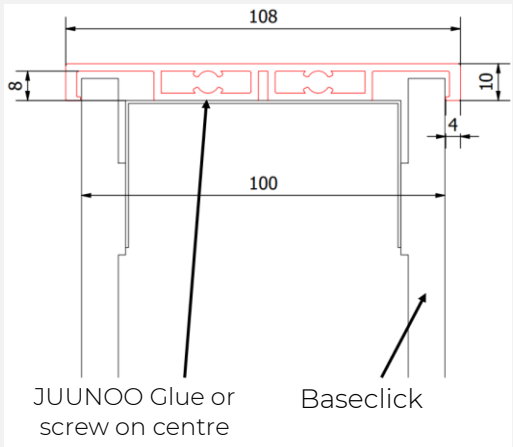

The BaseClick panels stick a little bit out from the back of the C-modules (max 0.3 in). The end cap is glued with JUUNOO Glue or is screwed on the centre of the profile<sup>1</sup>.

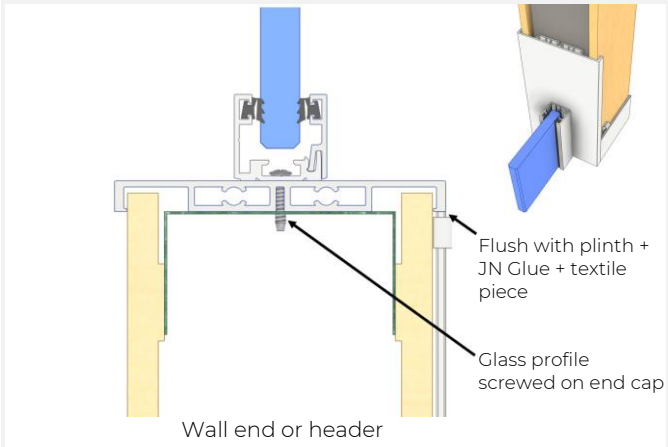

The single glass profile is screwed on the center. The outer legs of the end cap lay flush with the plinth (incl. JUUNOO Glue and the textile piece to <sup>2</sup>)

<sup>1</sup> More info, see p.65  
<sup>2</sup> More info, see p.62

## DOUBLE GLAZED WALL

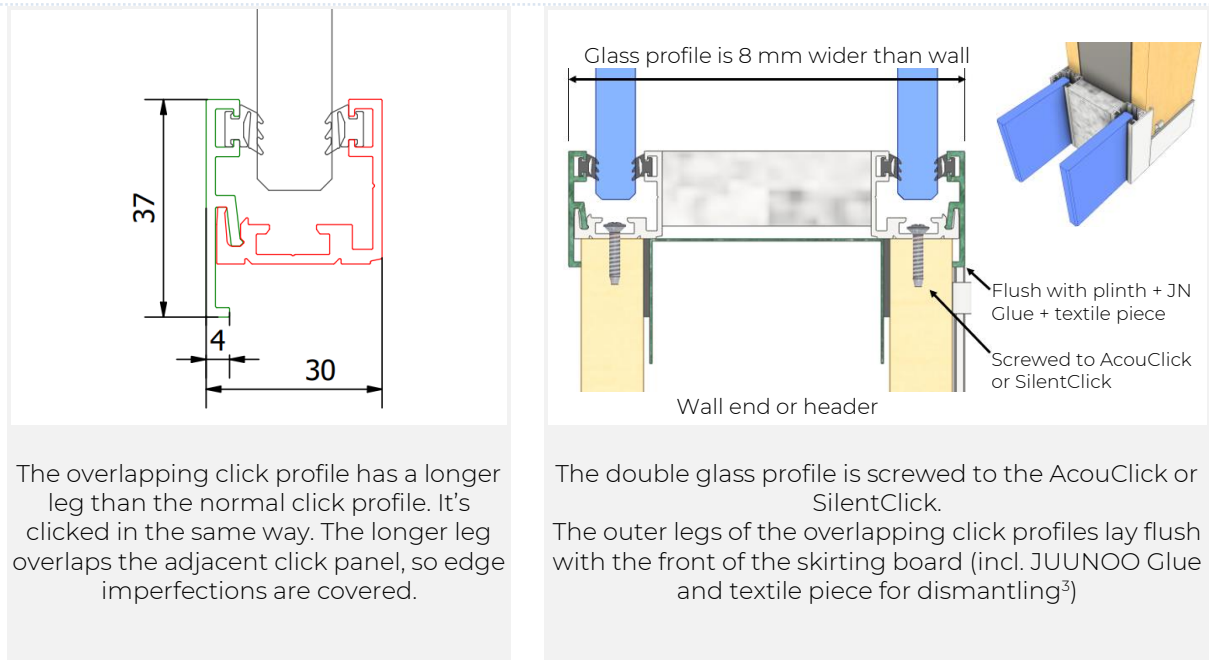

The mounting of the overlapping click profile is done in the order as below. The adjacent overlapping click profiles are cut to 45°. The connection of an overlapping click profile and a standard click profile is as usual 90°.

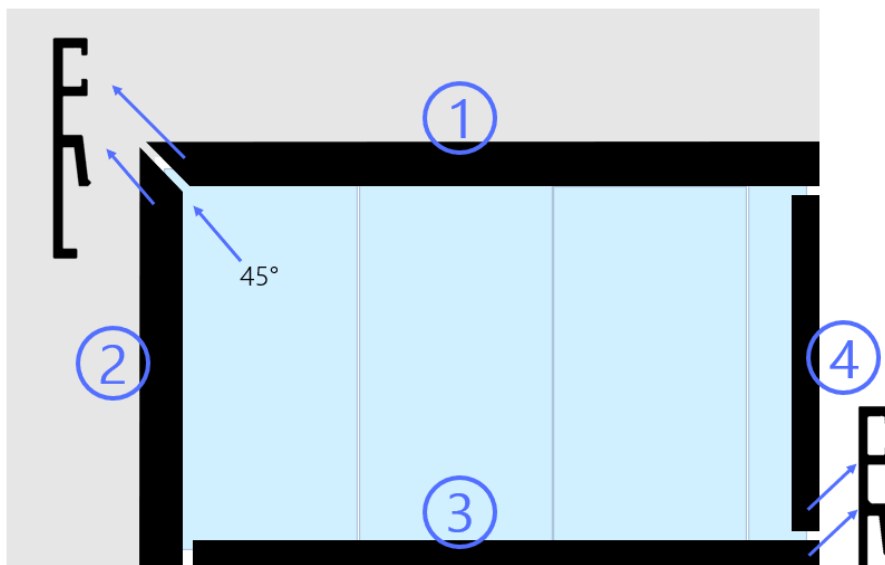

### 7.2.4 Door

The profiles of the door are supplied to measure. These are already fitted with a recess for the lock latch bolt and a marking gauge to mark the fixing holes of hinges.

The door frame is screwed together with self-tapping screws with a 3.9x32 or 38mm cylinder head. These can be found at [www.Berner.eu](http://www.Berner.eu).

<sup>3</sup> More info, see p.62

Alternatively, connecting pieces can be used (see below). However, screws are more efficient to install and the connection is slightly more solid.

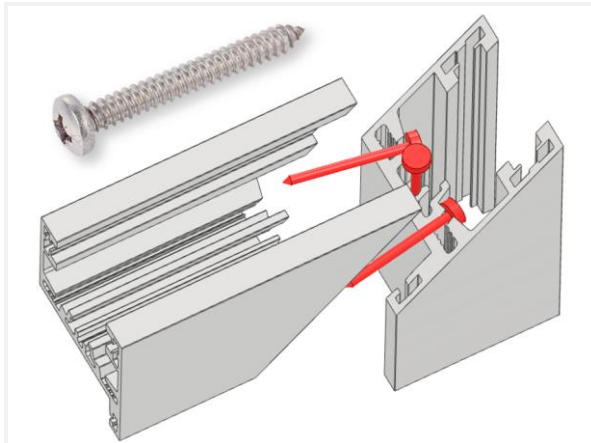

Connecting with screws



Alternative: connection with corner pieces

#### INSTALLING THE DOOR AT ROOM HEIGHT

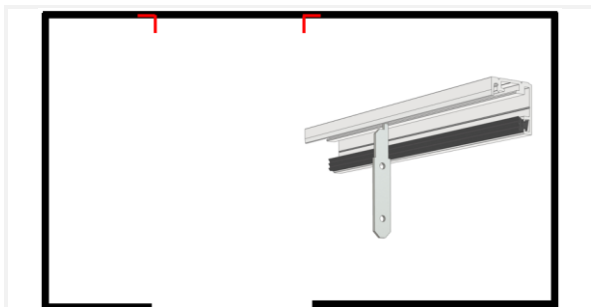

Install the base profiles. Leave an opening at the bottom for the door. Make sure all the connection pieces<sup>4</sup> are in position beforehand.

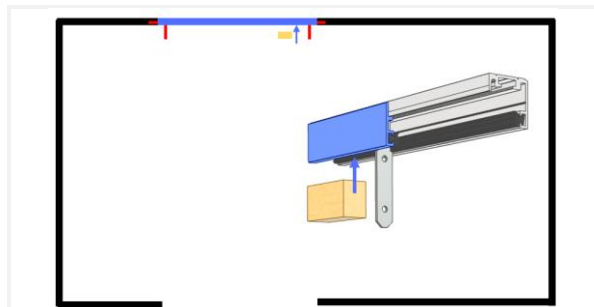

Click a snap-in profile the same width as the door frame into the base profile against the ceiling. Hold the snap-in profile in place with a 12-mm-thick block.

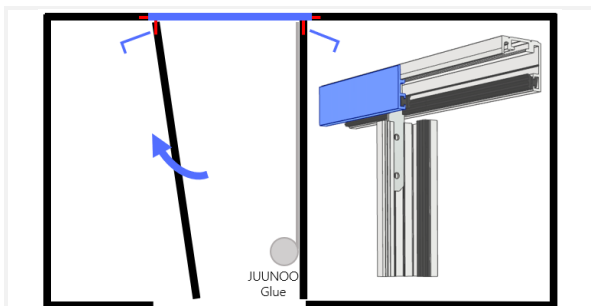

Insert a base profile over the connection pieces. Apply JUUNOO Glue to the back of the glass profile on the *lock side* of the door.

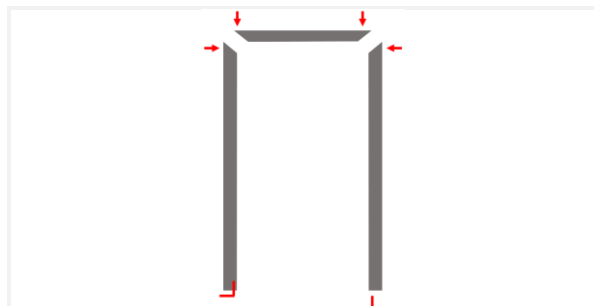

Assemble the door profile. Insert 2 connection pieces at the bottom.

<sup>4</sup> The connection pieces are delivered flat including M5 hex screws. They can be folded in different ways depending on different situations.

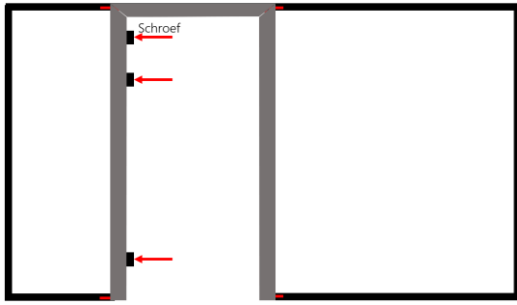

Screw the hinges to the door profile. To do this, pre-drill a 3 mm hole. Use the screws<sup>5</sup> below to secure the hinge, door profile and glass profile together.

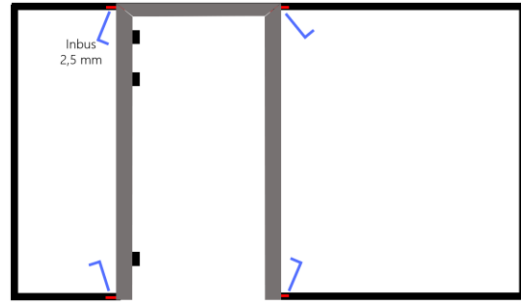

Put the entire unit in a level position. The connection pieces can then be tightened. The frame is now ready for hanging the door leaf inside.

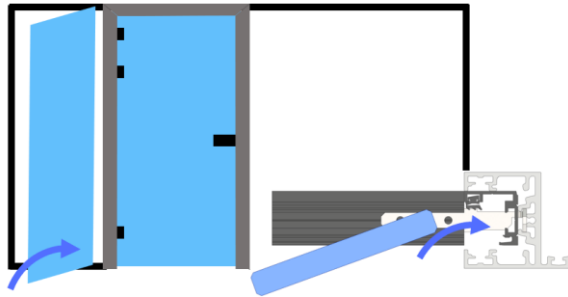

Position the glass pane beside the door.

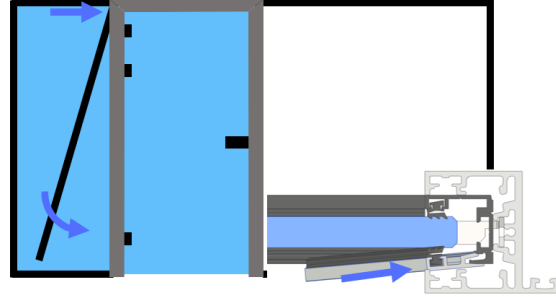

Install the vertical snap-in profile. Some soapy water on the rubber reduces friction.

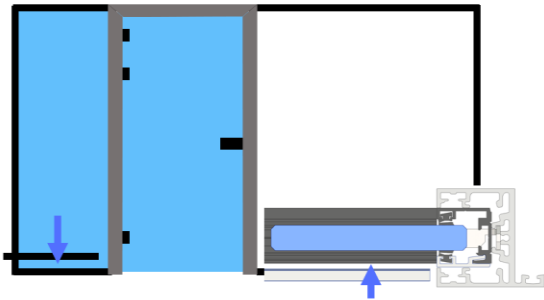

Install the horizontal snap-in profiles.

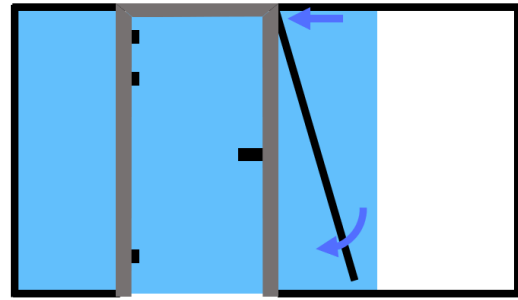

Do the same on the other side of the door.

<sup>5</sup> To fasten the hinges, use countersunk 3.9x22mm parkers without a drill point. These can be found at [www.Berner.eu](http://www.Berner.eu).





Various connections: cross-sections from left to right:

- Hinge side, vertical side & glass
- Lock side, vertical side & glass
- Horizontal profile door & glass profile ceiling
- Vertical side & full wall / existing wall
- Double glass wall & single glass door. Work is currently underway on a double-glazed door that will match the double-glazed wall in terms of acoustic performance.

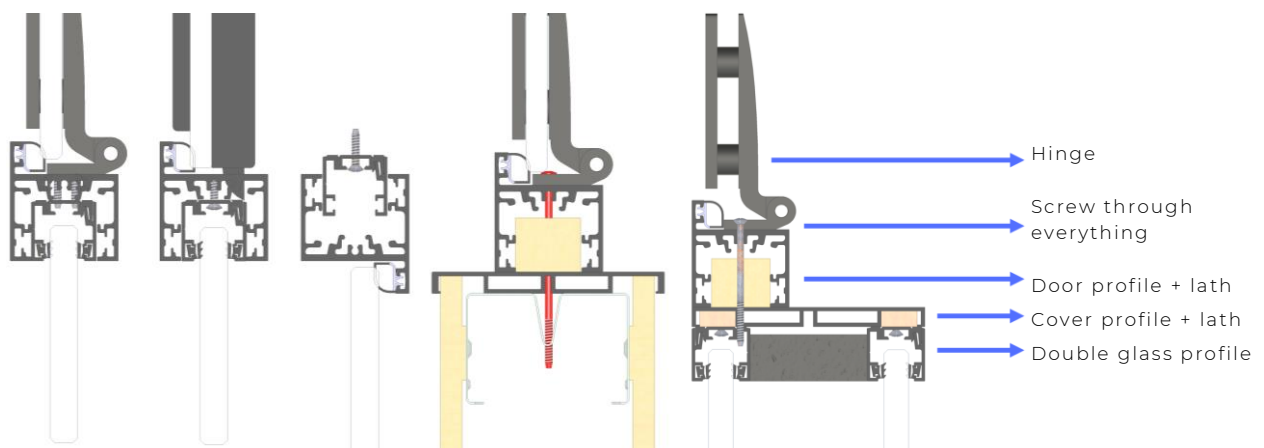

## INSTALLATION OF AN NON-ROOM-HEIGHT DOOR

When a glass pane is installed over a door, a glass profile is inserted into the horizontal profile of the door frame.

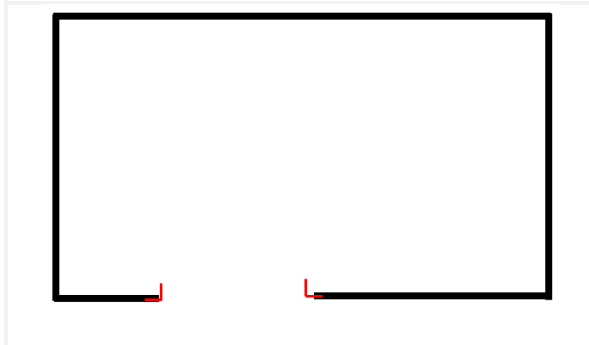

Install all basic glass profiles. Place 2 connection pieces at the bottom.

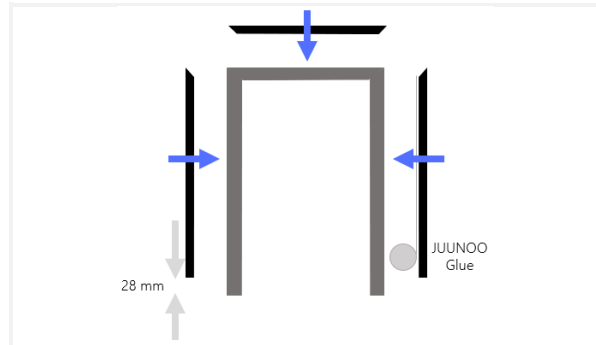

Assemble the door frame. Insert the supplied glass profiles into the door frame. In doing so, glue the glass profile to the hitting side with JUUNOO Glue. Make sure the angles of the glass profiles fit properly.

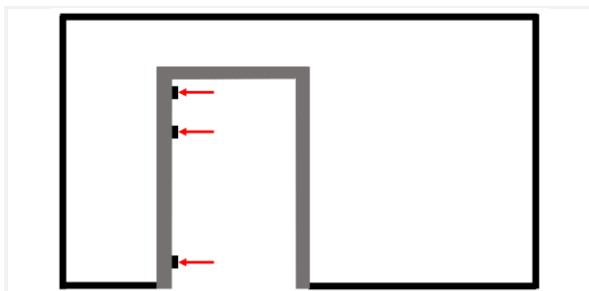

Screw on the hinges. This also fixes the glass profile.

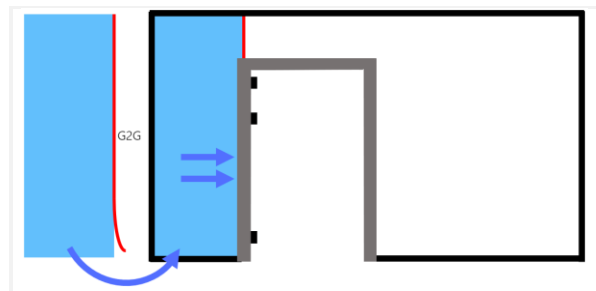

Apply a G2G to the glass pane on the hinge side along its entire length. Press it against the door frame. Make sure the door frame is level.

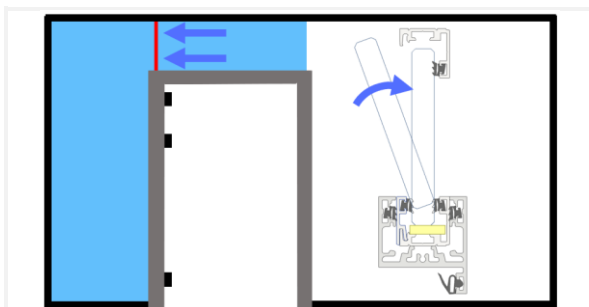

Insert the glass pane above the door frame and press firmly against the glass pane on the left.

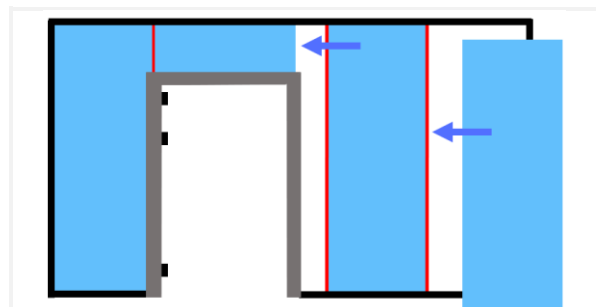

Apply a G2G to across the entire length of the next glass pane. Press it firmly against the door frame. Now complete the rest of the glass wall.

## INSTALLING A DOOR AGAINST AN EXISTING WALL



Secure all the base glass profiles in place. Note that the side of the doorway against the wall is not level.

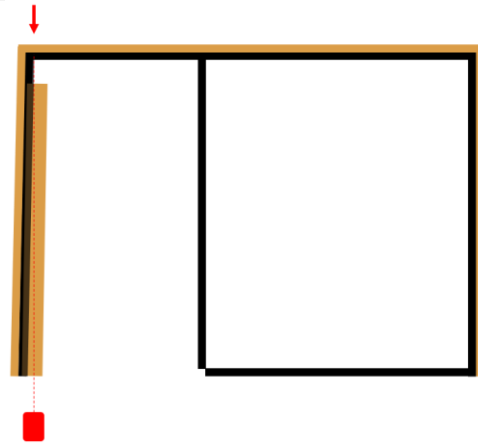

Insert a thick wooden batten (18 mm) into the profile and mark a level line using a laser.

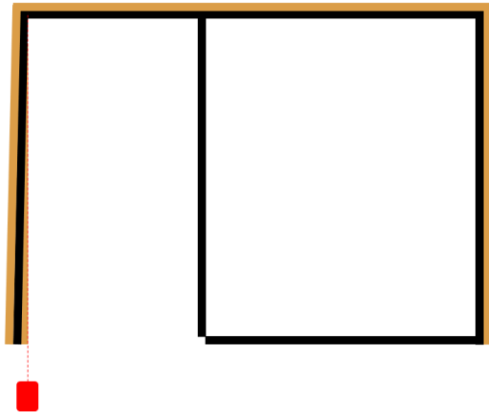

Cut off the excess wood. Insert the batten back into the glass profile.

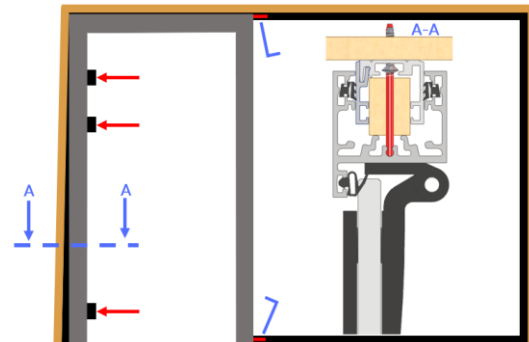

Secure the door frame using long screws or dowels (red) along with the hinges. Due to the batten, the door frame is now level. Section A-A shows the final construction.

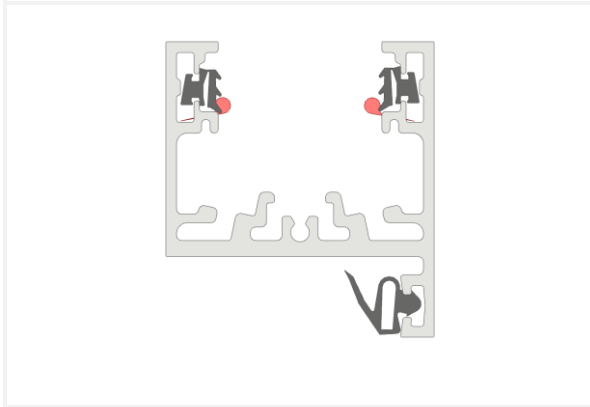

If the lock side of the door is against a sloping wall, this side cannot be screwed down because the screws will be highly visible. Therefore, it is best to use with some dabs of mounting kit.

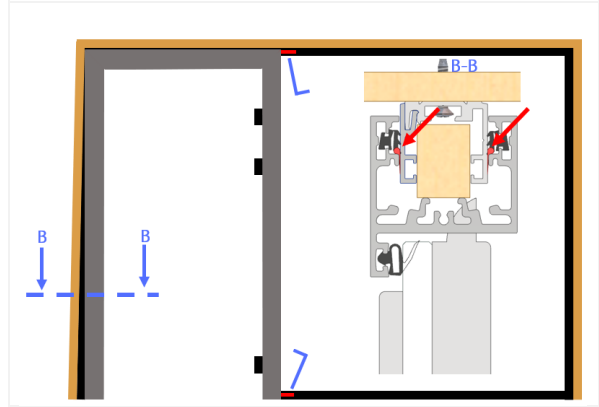

Slide the door profile over the glass profile and allow to dry.

### INSTALLATION OF A DOOR BETWEEN 2 EXISTING WALLS

The construction of a wall between two existing walls is very similar to the previous method.

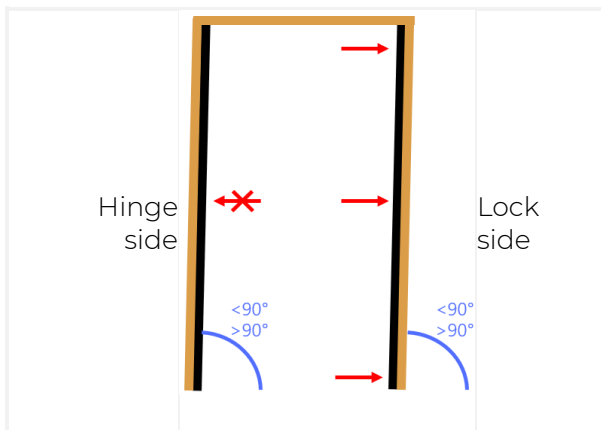

Cut only the vertical base glass profiles. Of these, only fix the profile on the lock side of the door. In the worst case, the vertical sides are not level.

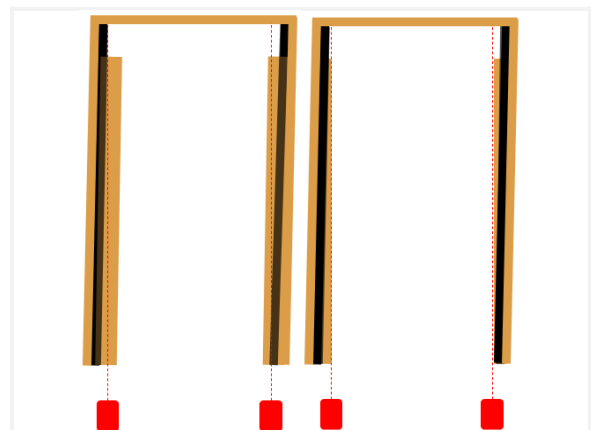

Insert a thick wooden batten into the profile and mark a level line using a laser.

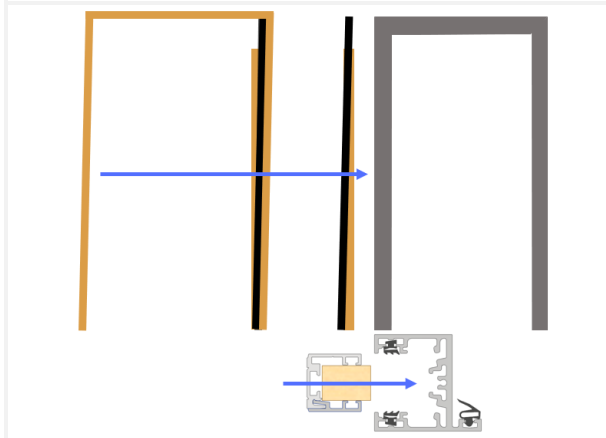

Take the glass profile on the hinge side and insert it including the wooden batten into the door frame.

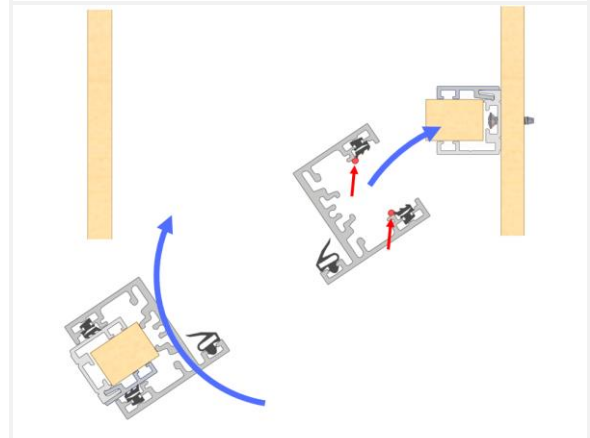

Apply mounting sealant to the inside of the door frame on the lock side. Turn the entire door frame and glass profile unit with wooden batten into the opening.

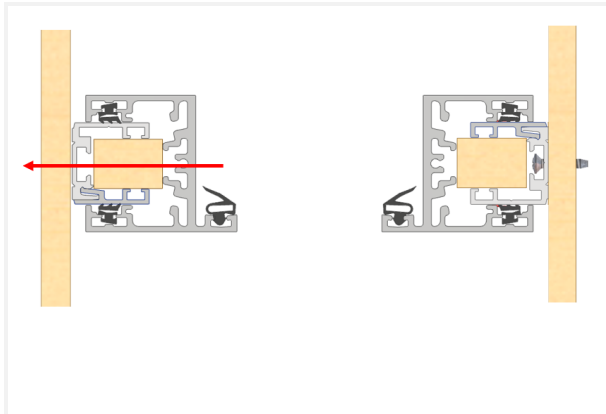

Using a long screw or dowel, fix the hinge side of the door frame. Do this at the height where the hinges will be, so the screw head is covered

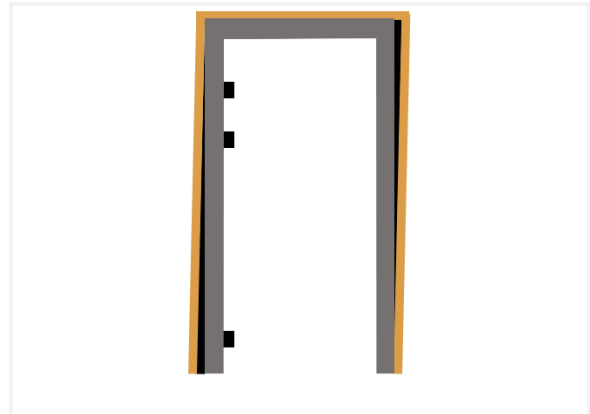

Apply the hinges at the correct height. A small seam will be visible if the connecting walls are crooked.

## 7.2.5 Door hardware

The following door hardware is provided as standard.

It can all be obtained in black, white and anodized.

In addition to the following, drop sills and door stops can also be provided.

### HINGE

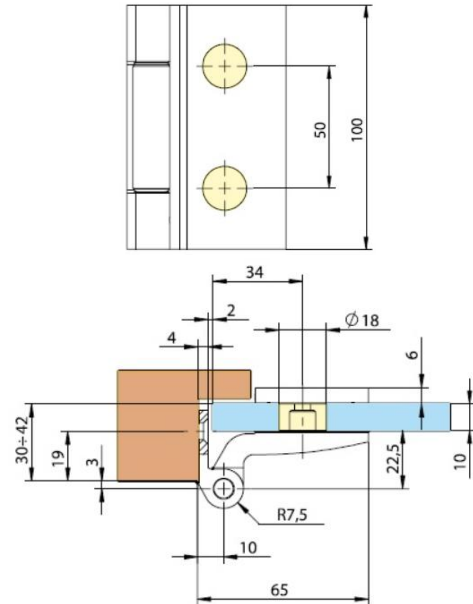

### LOCK CASE

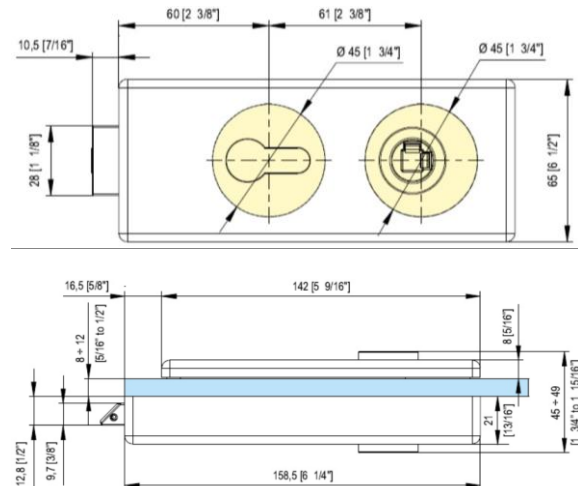

## LEVER HANDLE

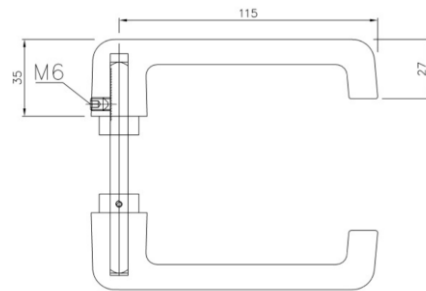

## OVERHEAD CLOSER

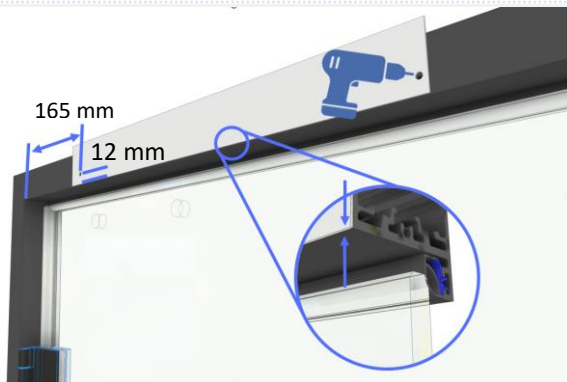

Place the hole template at 165 mm from the inside of the door profile.  
Bottom side is flush with door profile.  
Drill the two holes of 3 mm.

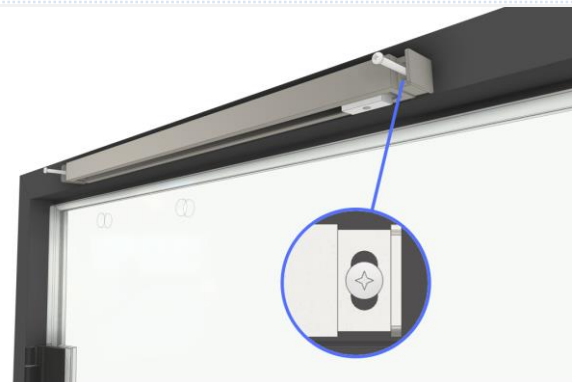

Screw the sliding rail with the attached screws.  
When a *hold open function* is required, follow the steps in this QR-code:



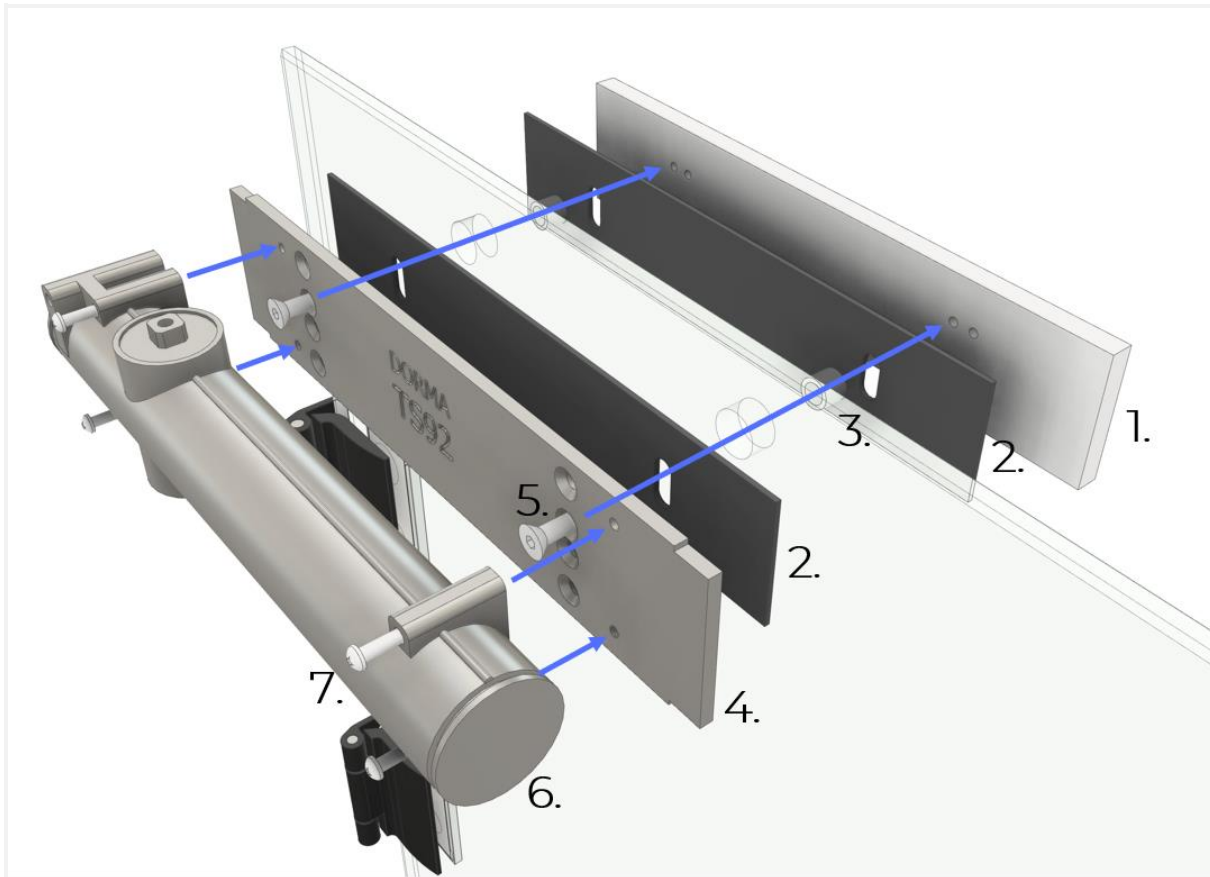

1. Aluminum cover plate. Choose the right hole so that this plate aligns with the mounting plate (4.)
2. Rubber spacers
3. Plastic bushes. Sit in holes of glass.
4. Mounting plate. When overhead closer on left side of door, put text upright.\* Choose the hole second from the top.

5. Screw parts 1 till 4 together with an allen key 5.
6. Screw the pump to the mounting plate with attached screws (7. Philips 2)

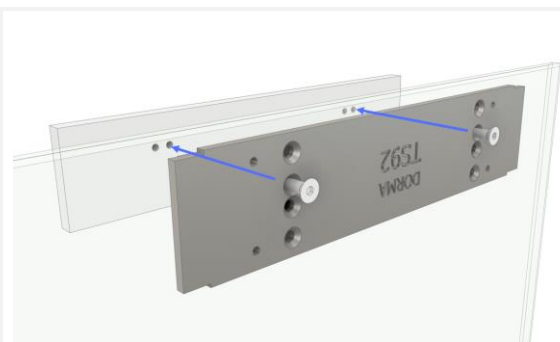

\*Mount the mounting plate *upside down* when the overhead closer is located on the *right side* of the door. Make sure the cover plate is aligned with the mounting plate.

The assembly should look like this by now.

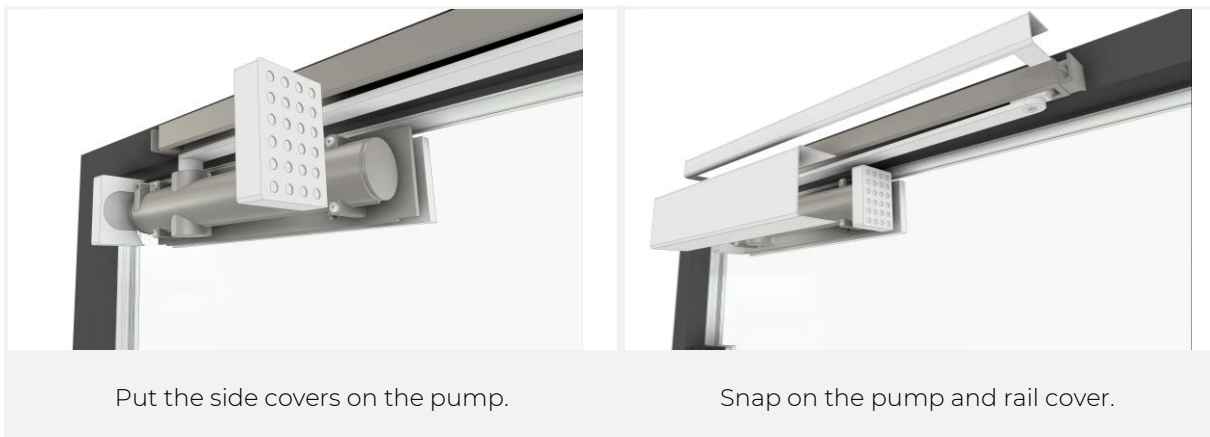
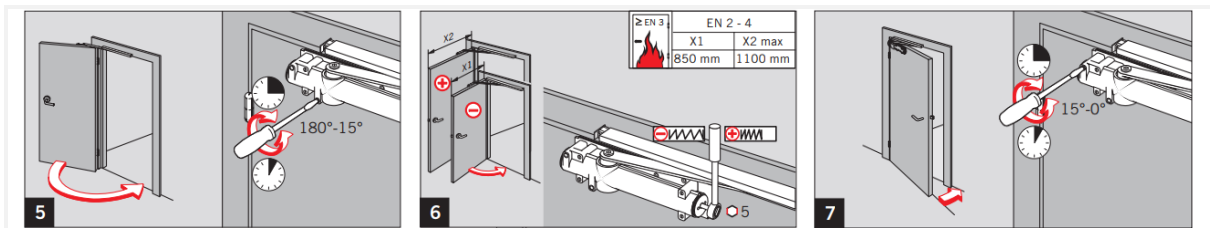

### 7.2.6 Header

For a circular construction of a glass wall, the glass wall is a standard height of 2.36 m. The remaining height of this wall is filled with an header. In essence, the header is a wall mounted against the ceiling. A glass wall can then be placed underneath. Depending on the height of the header, a different configuration of modules is used. Below is an overview.

Header is **lower than 700 mm** high: use horizontal C modules.

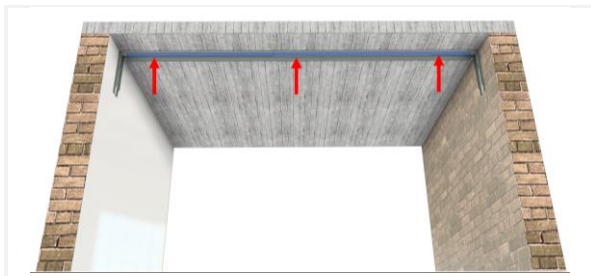

Secure a C module to the ceiling.



Hang a 2nd C-module under it at the desired height.  
Secure it with the feet against the wall.

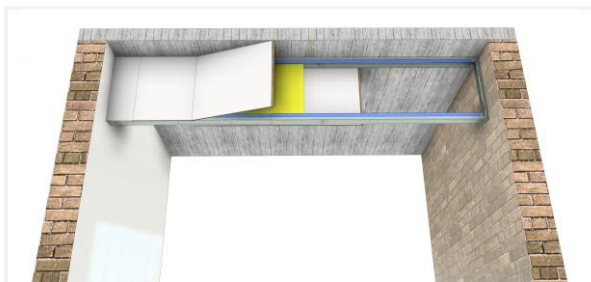

Install the insulation material and line the C modules with snap panels or drywall.

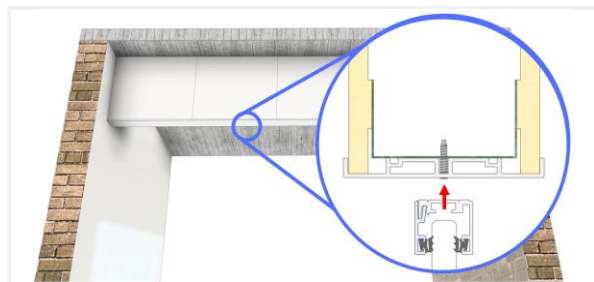

Screw the finishing profile against the underside.  
Make sure the screws are countersunk. Against this comes the glass profile.

If the header becomes even smaller, the foot sections of the C modules can be cut or completely folded in, allowing the styles to be closer together.



The foot profiles are trimmed and folded inward.  
This structure has a minimum height of 250 mm.

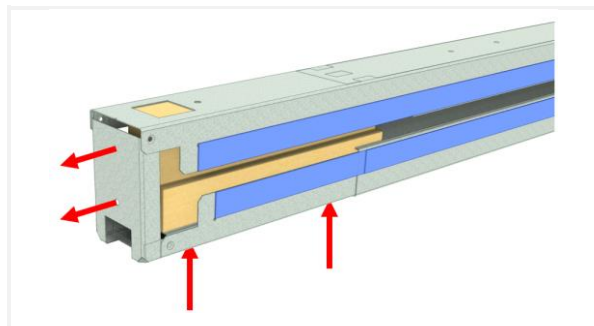

The foot profile of the upper C-module is shortened and fixed against the wall. The foot profile of the lower C-module is completely folded down.  
This assembly has a minimum height of 50 mm

Header is **higher than 700 mm** high: use vertically suspended I- and C-modules.

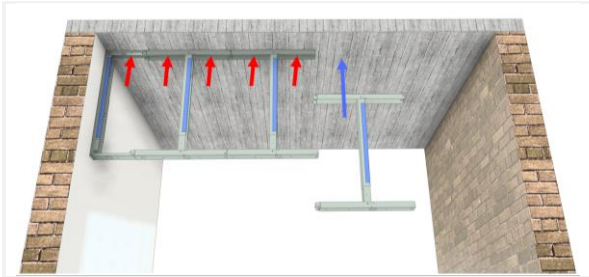

Fix the I and C modules against the ceiling like a normal wall. Click them together.

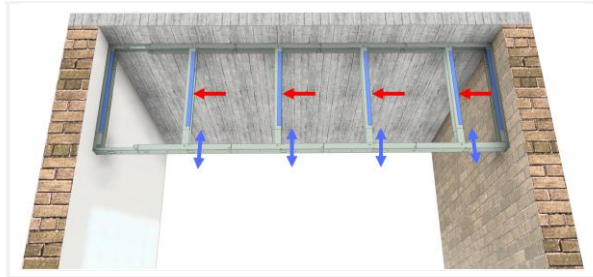

Slide the modules in or out to the desired height. Secure the posts with a self drilling screw.

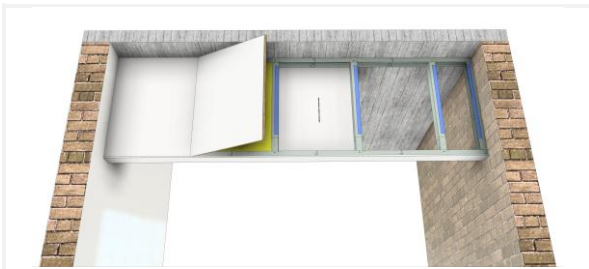

Install the insulation material and line the modules with snap panels or drywall.

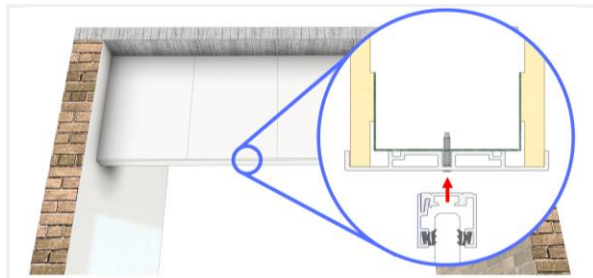

Screw a finishing profile against the underside. Make sure the screws are countersunk. The glass profile will be fitted against this.

90° and 180° connections can be made using a wooden beam. This method is similar for vertically suspended modules.

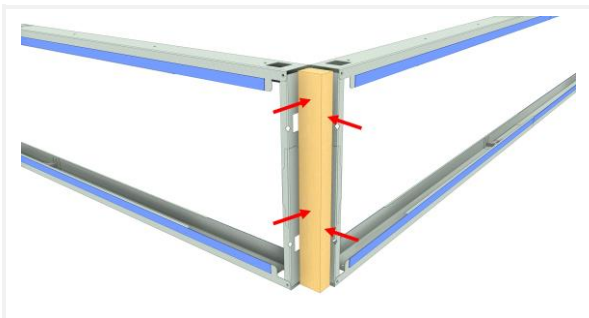

90° connection  
This method is similar with vertically suspended modules.

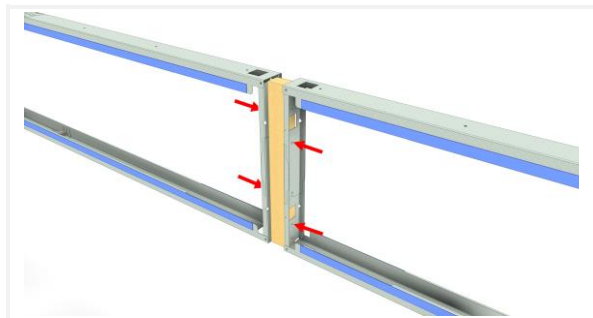

180° connection

## Measuring a glass wall

### 7.3.1 Height

A standard glass wall is 2.36 m high. For this purpose, the **glazed panels are 900 mm x 2335 mm**. This height fits about 80% of projects. It ensures that when recycled, the glazed panels will fit each time.

7.3

Weight of these standard glass pane sizes:

68,3 kg for 66.2 and 66.2A glass

83,3 kg for 88.2 and 88.2A glass

A standard **glass door** dimension is **10 x 930 x 2305 mm**.

You can also choose to work at room-height. To do this, measure the height and width of the wall every meter.

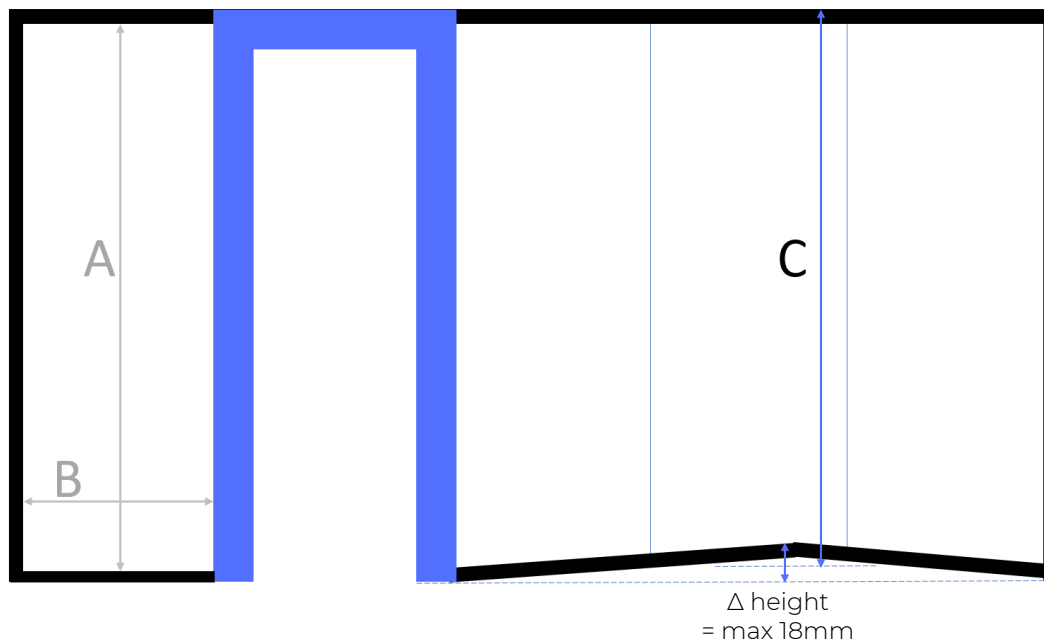

A = Standard glass pane height = 2335 mm

B = Standard glass width = 900 mm

C = Measurement to calculate glass leave height from =  $(\text{max. height} - \text{min. height})/2$   
(not average!)

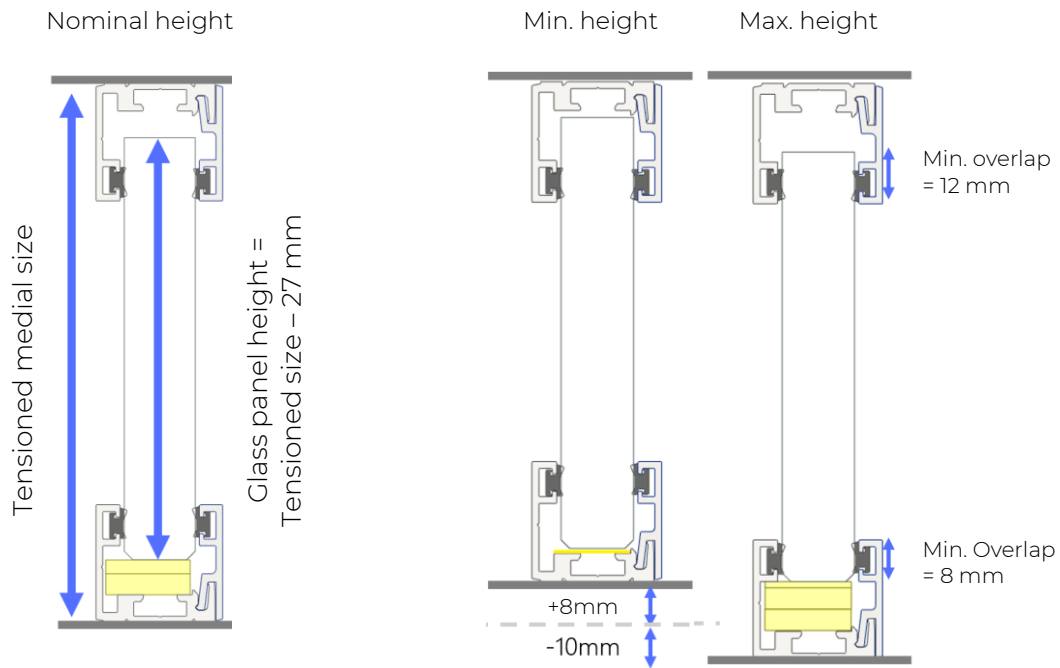

### 7.3.2 Width

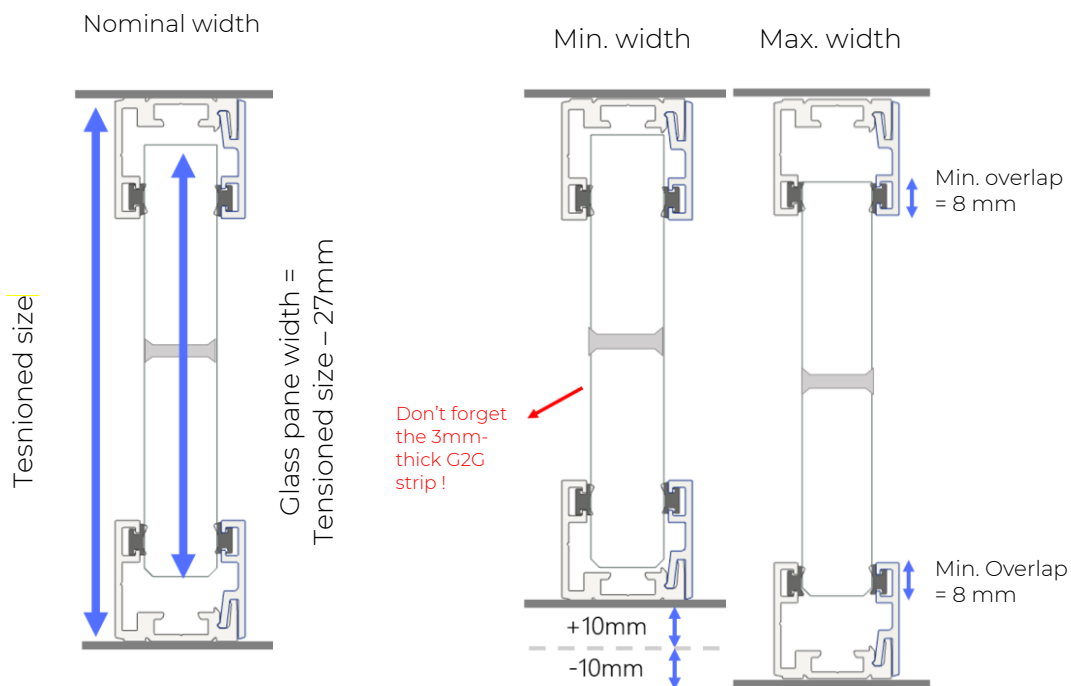

### 7.3.3 Door in a wall

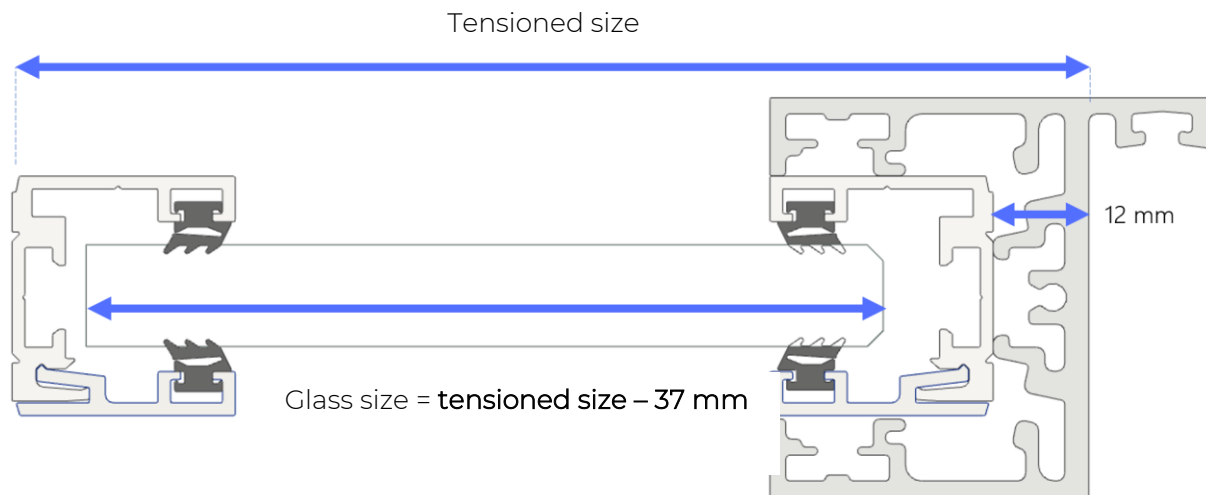

#### Additional information on acoustics

7.4 When choosing a wall with higher acoustic properties, it is important that the glass also has higher acoustic properties. If this is not the case, most of the sound will escape through the glass, irrespective of how efficiently the wall insulates the sound. In general, the difference in acoustic attenuation ( $R_w$ ) should not exceed 10 dB.

## 8 Dimensions

### I-module dimensions

8.1

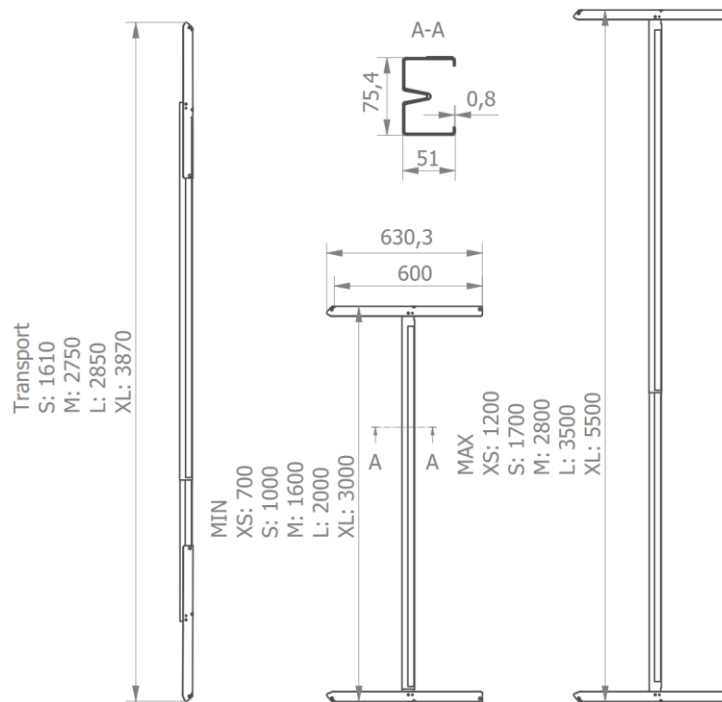

8.2

### C-module dimensions

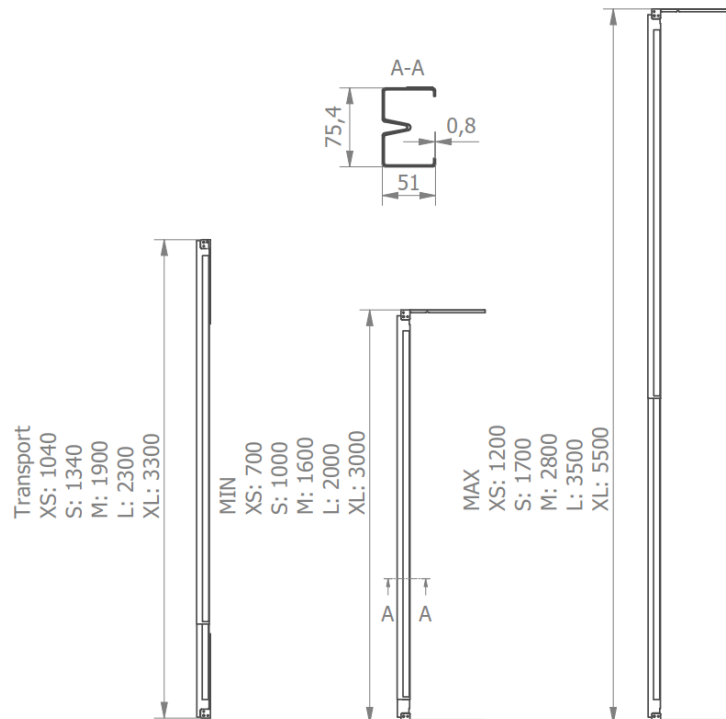

## Generic dimensions of a wall

8.3

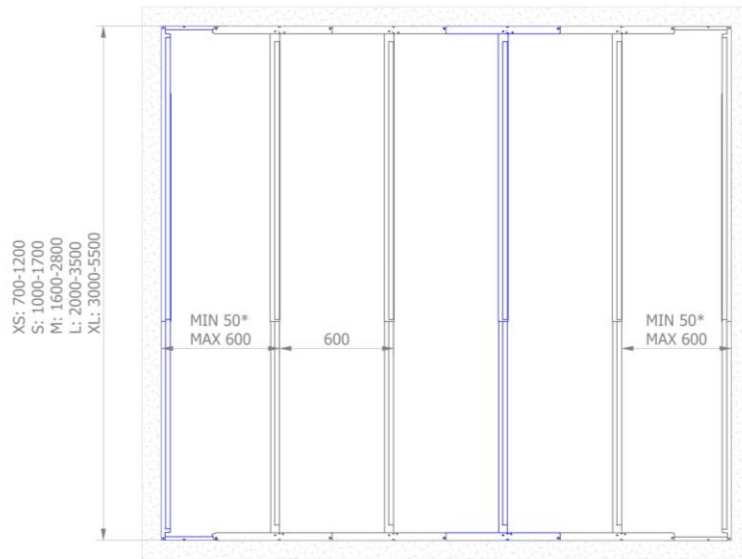

## D-set dimensions: for a single door

8.4

The door set consists of 1 horizontal top profile above the C-modules, which is then completed with 1, 2 or 3 cross profiles depending on the height of the C-modules. The top profile has the fitting dimension of 2 adjacent I-modules, thereby ensuring that the pattern of 600 mm is maintained over the entire wall.

8.5

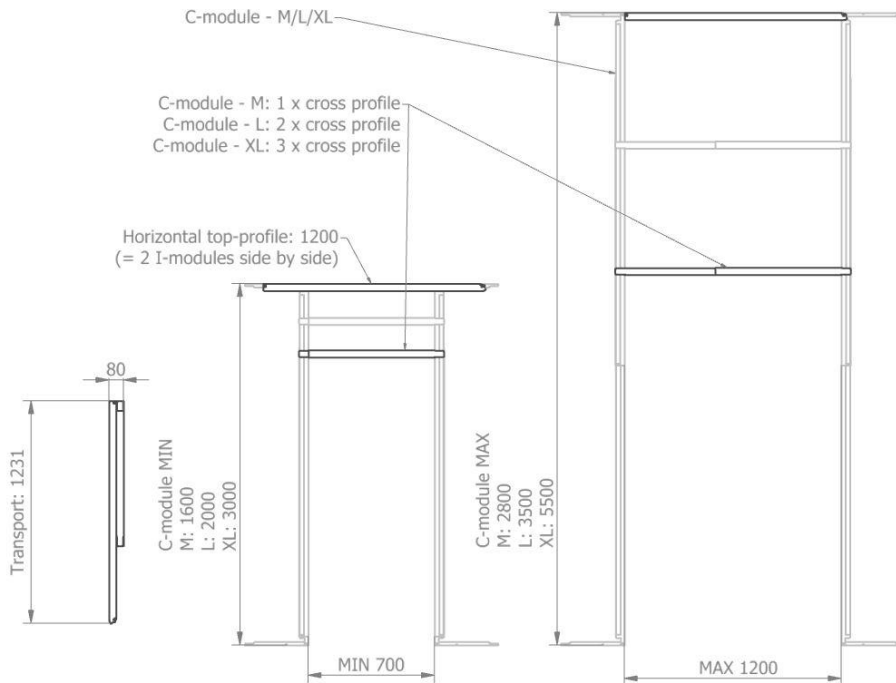

## DD-set dimensions: for a double door

The DD-door set consists of 1 horizontal top profile above the C-modules, which is then completed with 1, 2 or 3 cross profiles depending on the height of the C-modules. The top profile has the fitting dimension of 3 adjacent I-modules, thereby ensuring that the pattern of 600 mm is maintained over the entire wall.

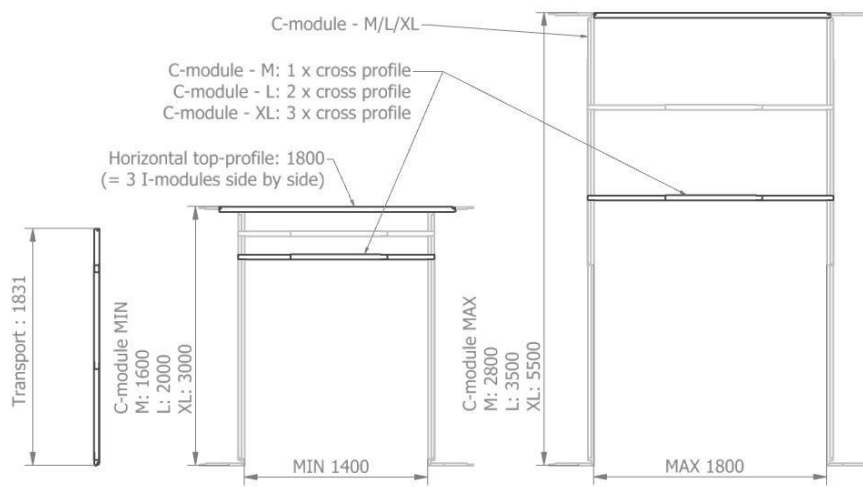

BaseClick dimensions

BaseClick panels come in sizes of 2785 mm and 3500 mm. These are delivered cut to height according to the project. Typically 20 mm smaller than the average ceiling height. The panels come with JUUNOO blue tapes.

8.6

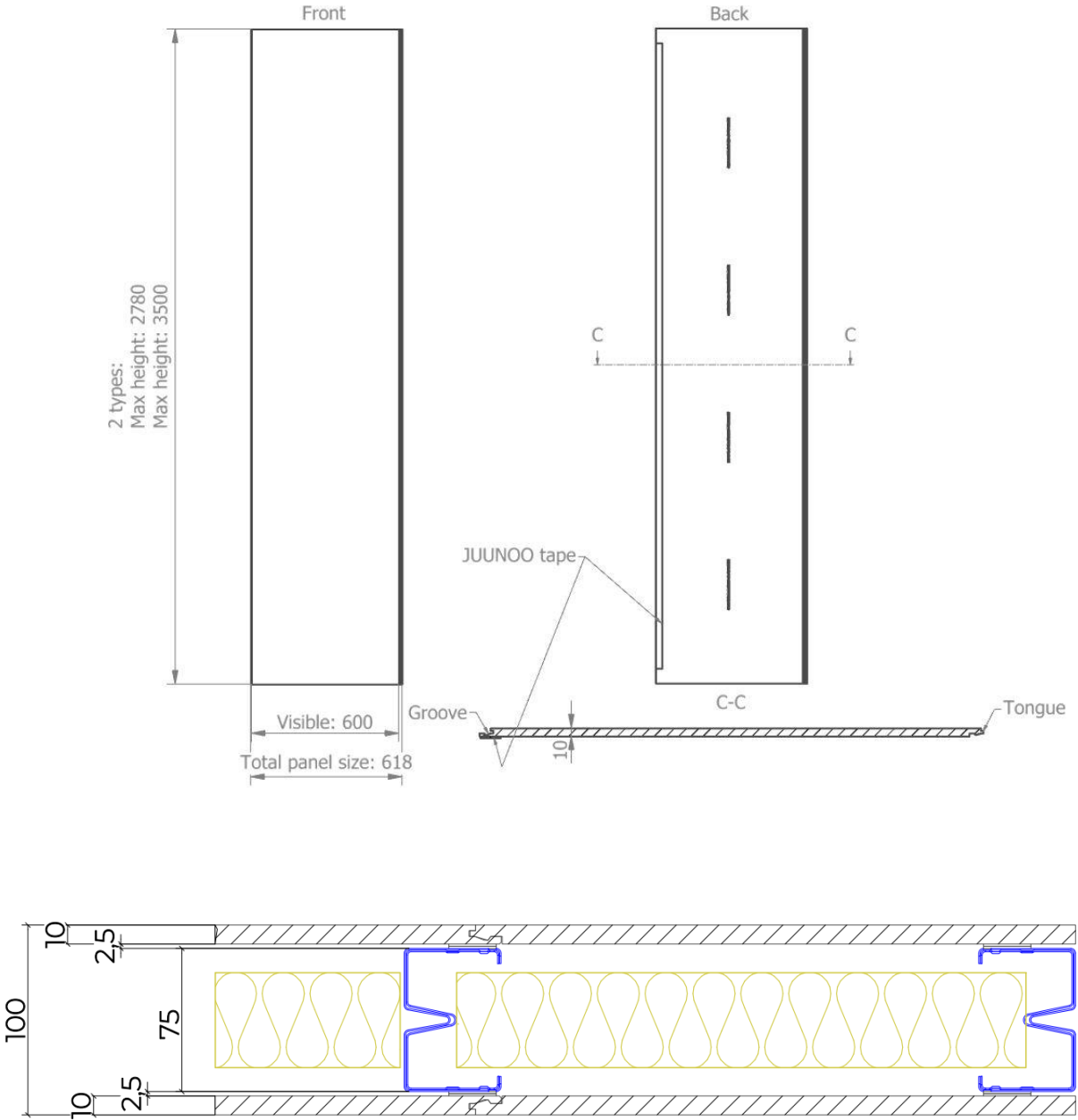

AcouClick dimensions

8.7

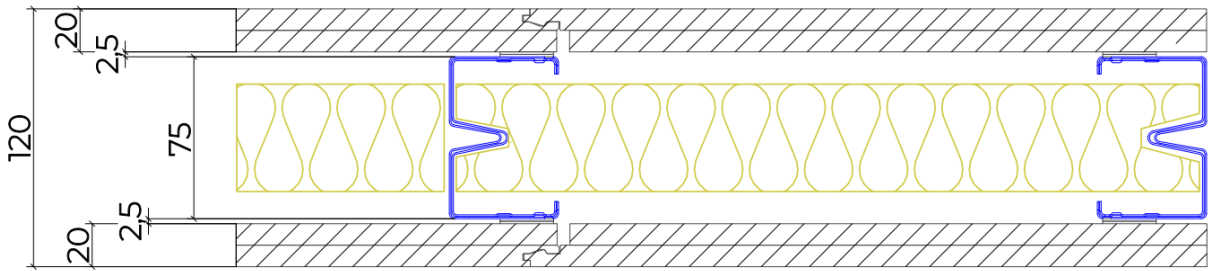
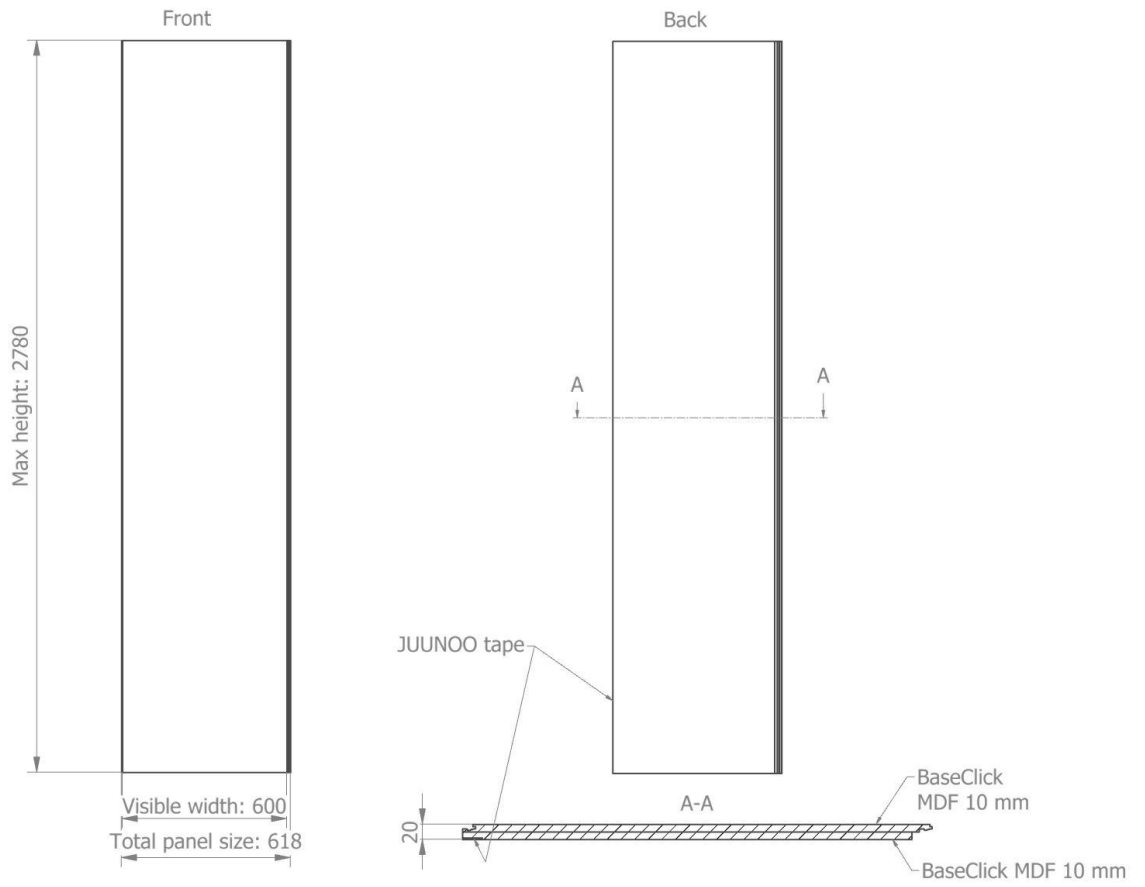

## Dimensions glass wall

### 8.8.1 Glass wall

8.8

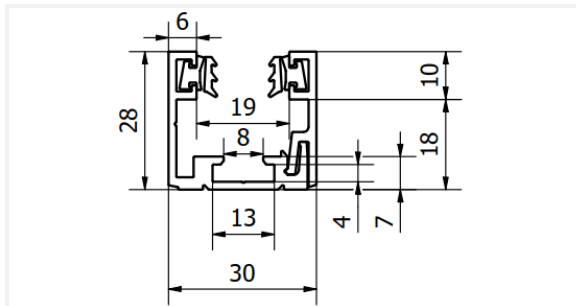

Single glass profile

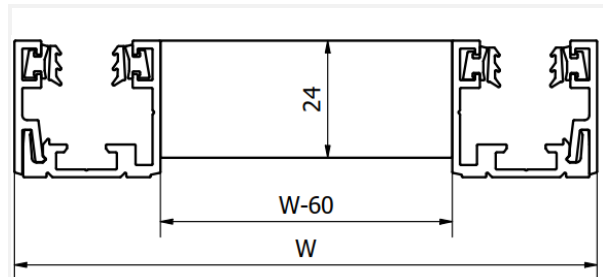

Double glass profile  
W = variable, min. 60 mm.

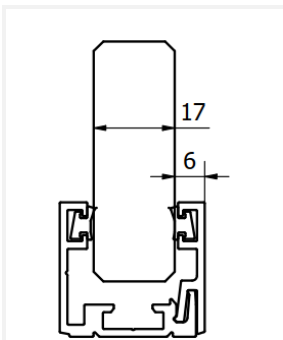

Single 88.2 glass

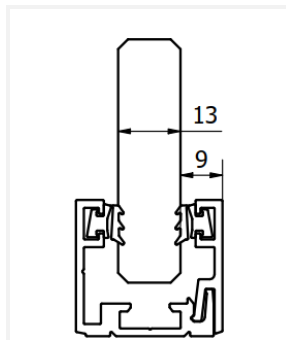

Single 55.2 glass

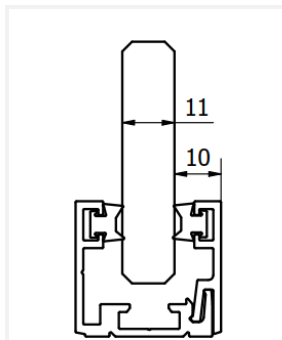

Single 55.2 glass

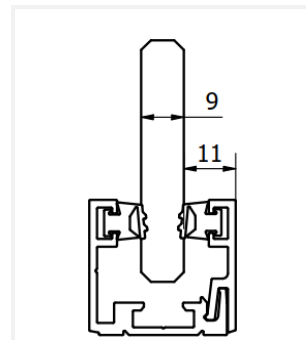

Single 44.2 glass

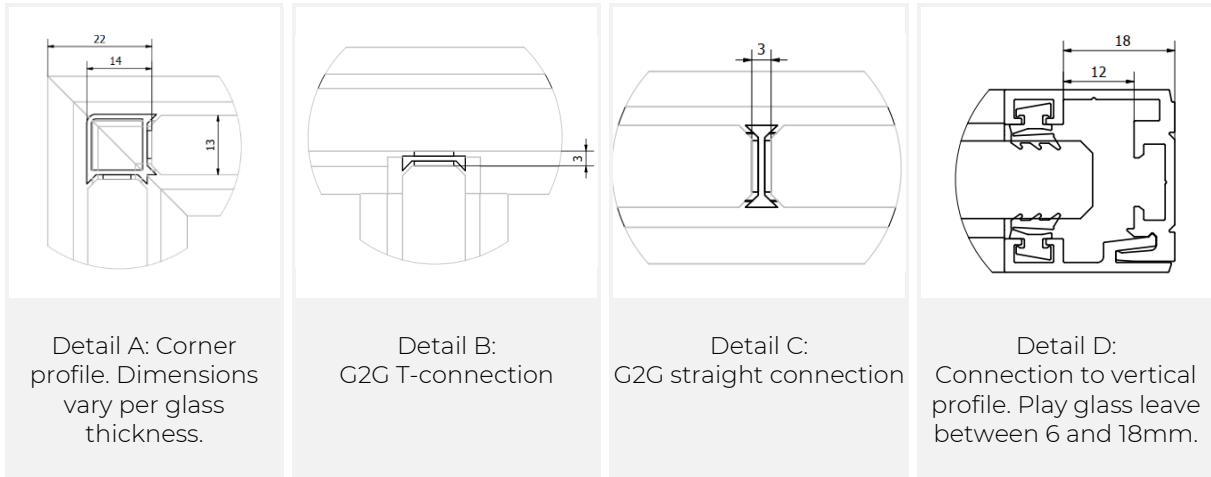
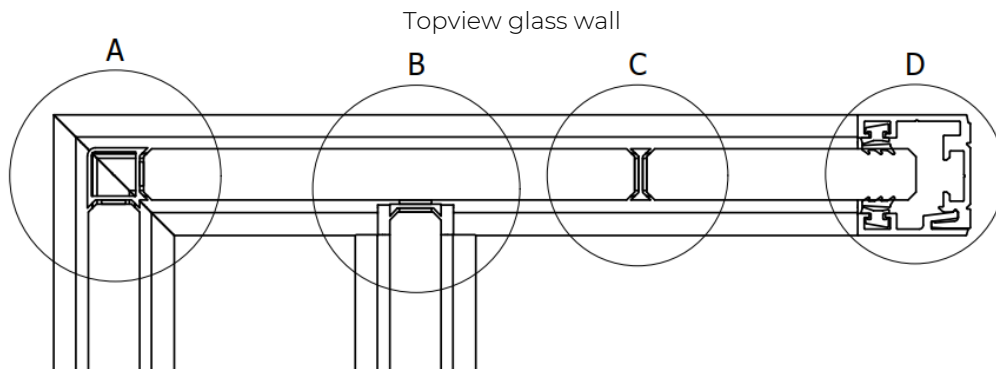

Contact [JUUNOO@info.com](mailto:JUUNOO@info.com) if more dimensions are required.

### 8.8.2 Glass door

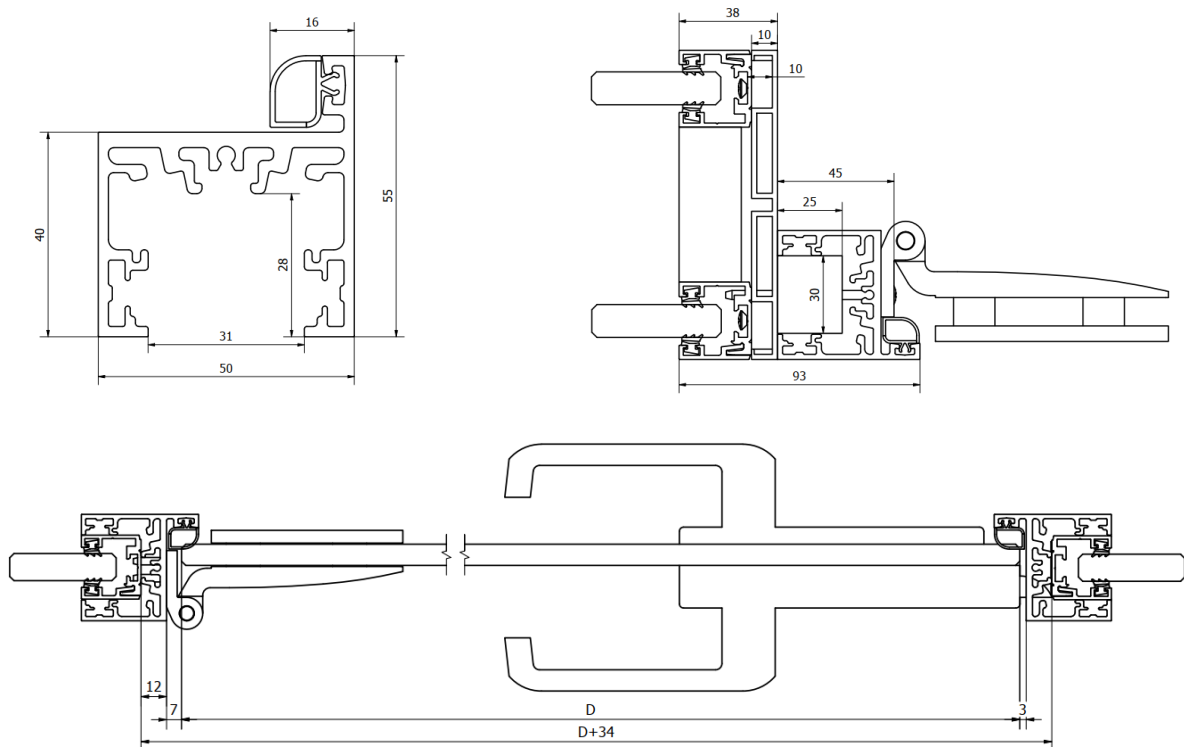

Contact [JUUNOO@info.com](mailto:JUUNOO@info.com) if more dimensions are required.

## AutoCAD, Revit, BIM models

All components can be delivered in either 2D or 3D format for detailing requirements. Please contact [info@juunoo.com](mailto:info@juunoo.com) for technical drawings.

We can also offer you assistance in designing projects using the JUUNOO system.

8.9

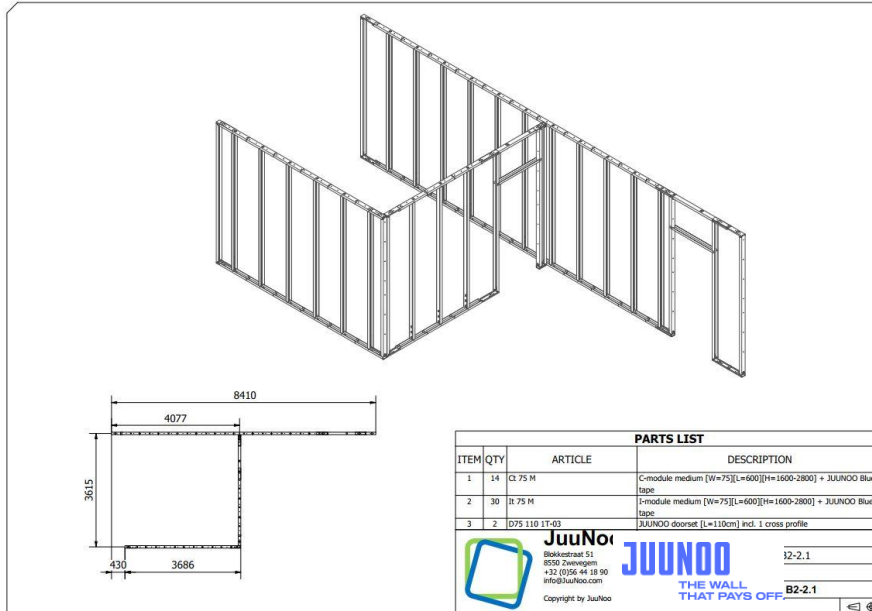

## 9 Sustainability

### Materials used

#### 9.1.1 Modules

JUUNOO modules are made from XCARB steel (in full: COIL MAGNELIS ZM120 S250GD X-CARB). Our guarantee to you is that at least 85% of this steel comes from recycling processes and is melted with 100% renewable energy. The material consumption of the

9.1 medium modules is as follows:

Medium size	New material	Recycled material	Total
C-module	0,6 kg	3,7 kg	4,3 kg
I-module	0,8 kg	4,3 kg	5,1 kg
D-set	1,5 kg	1,0 kg <sup>6</sup>	2,5 kg

#### XCARB – EPD SUMMARY



#### Manufacturer:

- ArcelorMittal Europe – Flat Products

#### Product Description:

- Double-sided hot-dip galvanized carbon steel with Magnelis® coating (93.5% Zn, 3.5% Al, 3% Mg)
- Thickness range: 0.36–6mm | Coating mass: 70–800 g/m<sup>2</sup>
- Compliant with EN 10346 standards

#### Production:

- Manufactured at ArcelorMittal Sestao, Spain using Electric Arc Furnace process
- Powered by **renewable electricity** with Guarantees of Origin
- **~87% recycled content** (947 kg external scrap per tonne)

#### Environmental Performance (per tonne):

- **GWP-total (A1-A3):** 900 kg CO<sub>2</sub> eq.
- **End-of-life recycling:** 98% material recovery (980 kg)
- **Module D benefit:** -65.6 kg CO<sub>2</sub> eq. (recycling credit)
- **Validity:** December 14, 2028 | **Standards:** ISO 14025:2006, EN 15804:2012+A2:2019

#### Validity:

- December 14, 2028 |

#### Standards:

- ISO 14025:2006, EN 15804:2012+A2:2019

Full EDP available on request.

<sup>6</sup> The door module is not yet made in XCARB steel.

## 9.1.2 Panels

### *CLICKPANEL – EPD SUMMARY*

**Manufacturer:** Unilin B.V. Division Panels

**Product Description:**

- Engineered wood product made by compressing wood fibers and glue
- Density: 637 kg/m<sup>3</sup> | Thickness range: 6–40 mm
- Compliant with EN 13986:2004+A1:2015 and EN 622-5:2010

**Production:**

- Manufactured in Bazeilles (France) and Vielsalm (Belgium)
- **100% recovered wood** from sustainable forest management and sawmills
- Composition: 81% fresh wood, 11% glue, 2% additives, 6% moisture
- Thermal energy largely from renewable woody waste

**Environmental Performance (per m<sup>3</sup>):**

- **GWP-total (A1-A3):** -765 kg CO<sub>2</sub> eq. (carbon storage)
- **Biogenic carbon content:** 253.3 kg C/m<sup>3</sup> (stored CO<sub>2</sub>: 928.7 kg)
- **End-of-life:** Energy recovery as secondary fuel
- **Module D benefit:** -563 kg CO<sub>2</sub> eq. (avoided emissions)

**Validity:**

- October 30, 2028

**Standards:**

- ISO 14025, EN 15804+A2:2019

Full EDP available on request.

## Reusability

The JUUNOO modules and click panels are designed and tested for multiple reuses. The connection with JUUNOO tape can be used up to 20 times without any significant loss of strength. Firmly pressing the cladding onto the modules is important to guarantee a good connection.

- 9.2 When screwing plasterboard or fibreboard onto the modules, it is important to use screws with a drill point. This reduces burr formation and allows the module profiles to continue sliding smoothly over each other. After screwing a board onto and off the module 10 times, the friction between the sliding profiles becomes too great to work efficiently.

The aged modules can—thanks to our buyback guarantee—be upgraded by JUUNOO. They can then be used in new projects. The aged click panels are recycled into new panels.

## Buyback warranty

### 9.3.1 Purpose of the buyback guarantee

9.3

JUUNOO has poured its passion and energy into developing and marketing a system that is 100% circular. In other words, our products can be dismantled and reassembled over and over again without compromising their functional characteristics. In principle, there is no reason why the JUUNOO lightweight wall models will not still be in use in a hundred years' time. Now that's added value!

Ideally, we don't want to see a single one of our panels thrown away or recycled in that time. And that's why we offer a buyback guarantee. We make it more financially beneficial to sell the modules and panels back to the manufacturer than to dispose of them.

We deliberately set our repurchase price guarantee to be lower than the effective residual value of the product. Ideally, we'd like the panels and modules to be sold directly between builders, so that as one room or building is taken down, it yields up the materials for a new room or building. We want to ensure product chains are as short as possible so that the emissions generated between two usage cycles are likewise kept to a minimum.

### 9.3.2 What do we buy back?

We buy back materials providing they have been dismantled and delivered to Courtrai. If necessary, JUUNOO can provide a quote for undertaking this work (transport and/or dismantling).

The material must be checked and sorted per the instructions below. If required, JUUNOO can also provide a quote to do this for you.

## MODULES

Modules must not have any damage that could affect their functionality.

Specifically:

- it must be possible to slide the modules open and shut.
- the horizontal profiles of the modules must click together by means of the quick-click system.

- the clamping system must still be capable of applying the necessary pressure and tension to the profile, so that the frame does not slip downwards under its own weight.
- bulges or dents may not extend further than 3 mm from the side surface of the frame, so that panels can always be fitted properly to the modules.
- modules that were screwed to their surroundings during assembly must not have more than two additional screw holes in the horizontal parts. To avoid rejection due to this point, you can always just use the screw holes that are already there. Alternatively, the modules can be secured to their surroundings using adhesive. See the technical document for more information about when it is safe to do this.
- screw holes in the vertical parts must not have any burrs, as these can hinder the sliding action of the modules. If panels need to be screwed into the JUUNOO modules, the best way to do this is using self-drilling screws – this approach avoids burrs.

The modules must be delivered stacked and sorted on pallets.

## PANELS

---

The following panels can be returned under the JUUNOO buyback guarantee:

- BaseClick
- AcouClick
- SilentClick
- Habito

Panels must not have any damage that could affect their functionality.

Specifically (JUUNOO - Click):

- panels must click together properly and the tongue-and-groove joint must be secure and airtight.
- the tongue and groove may not exhibit more than 5 cm of damage over the full height of the panel, so that functionality and airtightness can be guaranteed.
- only panels with a full wall thickness will be considered (minimum 2300 mm).
- only full-width panels will be considered.
- there must not be any visual damage to the front of the panel.
- panels must not have any adhesive residue.
- the JUUNOO tape on the rear of the panel must be in good condition.

Specifically (Habito):

- the panel must not have any visual defects, e.g.:
  - cracks
  - missing parts
  - damaged corners
  - holes for utility cables
  - etc.
- panels must not have any adhesive residue.
- only panels with a full wall thickness will be considered (minimum 2300 mm).
- only full-width panels will be considered (600 or 1200 mm).
- the panels must be completely clear of joint sealing strip.

- holes drilled in the region of the joint sealing strip are acceptable; a maximum of 10 holes may be drilled in the open region.

The panels must be delivered stacked on pallets, sorted by color and height.

## GLASS

---

The following glass elements can be returned under the JUUNOO buyback guarantee:

- Glass panels of the different types of glass with “circular economy” dimensions (900 x 2355 mm)
- Glass doors with “circular economy” dimensions (900 x 2310 mm), provided as a complete set, with working handle, and no visual defects (see specification above).

The glass panels must be provided in good condition.

Specifically:

- glass panels and doors must be free of visual defects such as:
  - scratches
  - cracks
  - adhesive residue

## MEETING PODS

---

The following pods can be returned under the JUUNOO buyback guarantee:

- Call 1
- Focus 1
- Connect 2
- Connect 3
- Connect 4
- Connect 6
- Made to order based on circular economy principles

Modules must not have any damage that could affect their functionality.

Specifically:

- the box must be returned as a complete assembly kit.
- the various components must meet all the specifications described earlier in this document.
- all electric components must be in good working order (tested by connecting to mains power).
- all fittings and mounts must be included.

We recommend dismantling the meeting pods by following the installation instructions in reverse order – this is the best way to check everything is present and correct.

We can always supply the installation instructions on request.

If the pod has already been dismantled and reused for a wall, or if a check finds that parts are missing for some other reason, you can still return the remaining components as loose parts, providing they meet the specifications above. NB: We pay more for the box as a complete unit than the sum of the loose JUUNOO products! The material must be delivered stacked on pallets, sorted by type and color.

### 9.3.3 What do we do with the materials we accept?

The JUUNOO products that we buy back will be given a second life via our network. In other words, they will be used in one of our future projects.

### 9.3.4 What do we do with the materials we reject?

You can still return material to us, even if it doesn't meet our conditions. It must always be sorted by type and sent on a separate pallet.

Wherever possible, we will remove the defective parts and replace them with new parts. If a repair is not possible, we will recycle the materials properly and use them as raw material for new products.

### 9.3.5 How much do we pay for repurchased products?

All the products that we sell at JUUNOO have a repurchase value. It's included on all our quotes. So, before you ever install a JUUNOO product, you already know how much cash it will yield at the end of its stay with you.

If you've lost your quote, just get in touch with JUUNOO.

If you bought your wall via a contractor, your contractor should have given you the JUUNOO certificate at the same time. The certificate constitutes part of the quote. You can find the repurchase value of your JUUNOO products on this certificate. So, when your JUUNOO product is installed, you already know how much cash it will yield at the end of its stay with you.

If you've lost your quote, just get in touch with JUUNOO.

- Modules with blue tapes 30% of the catalog price (at month of purchase)
- Modules without blue tape 20% of the catalog price (at month of purchase)
- Panels 10% of the catalog price (at month of purchase)
- Glass 20% of the catalog price (at month of purchase)
- Meeting Pods dependent on type (at month of purchase)

## PANELS



## MODULES



**JUUNOO**  
THE WALL  
THAT PAYS OFF.



# daidalos peutz



10.1

Chris Van de Voorde  
JuuNoo, Nelson Mandelaplein 2, 8500 Kortrijk

---

project: 2019-AK-JuuNoo.Insul  
opdracht: Insul berekeningen JuuNoo scheidingswanden  
opdrachtgever: JuNovation BVBA, Oudenaardsesteenweg 281, 8500 Kortrijk  
datum: 26 april 2019

inhoud: Overzicht van Insul berekeningen en meetresultaten in laboratorium

---

### Doel van deze studie

Het JuuNoo kadersysteem kan met verschillende beplatingen worden opgebouwd. De beplating heeft een significante invloed op de luchtgeluidsisolatie wand een scheidingswand.

Er zijn in het verleden met het JuuNoo systeem enkele metingen van de luchtgeluidsisolatie in een geaccrediteerd laboratorium uitgevoerd.

Deze meetresultaten worden in de studie aangevuld met een reeks berekeningen van de luchtgeluidsisolatie van verschillende types beplating toegepast op het JuuNoo kader (enkel en dubbel kader).

De akoestische berekeningen van deze wandssystemen werden uitgevoerd met de software INSUL 6.2.

De volgende tabel geeft een overzicht van de akoestische prestatie (uit metingen en berekeningen) van verschillende scheidingswandssystemen gebaseerd op het JuuNoo kadersysteem.

De akoestische prestatie is uitgedrukt in de akoestische verzwakkingsindex voor luchtgeluid  $R_w$  en de bijbehorende aanpassingstermen  $C$  en  $C_{tr}$  (correctie voor specifieke geluidsbronnen).

test	Kader	Geluidsabsorptie in spouw	Ophanging	Beplating	Rw (C;Ctr) in dB
1	JuuNoo 75mm	50 mm rotswol 33kg/m <sup>3</sup>	JuuNoo tapes	1 x 10mm ClickWall	44 (-5;-12) *
2	JuuNoo 75mm	50 mm rotswol 33kg/m <sup>3</sup>	Schroeven	1 x 8mm Spaanplaat + 1 x 10mm ClickWall	52 (-3;-10) *
3	JuuNoo 75mm	50 mm rotswol 33kg/m <sup>3</sup>	JuuNoo tapes	1 x 8mm Spaanplaat + 1 x 10mm ClickWall	52 (-3;-10) *
4	JuuNoo 75mm	50 mm rotswol 33kg/m <sup>3</sup>	JuuNoo tapes	2 x 8mm Spaanplaat + 1 x 10mm ClickWall	57 (-3;-10) *
5	JuuNoo 75mm	50 mm rotswol 33kg/m <sup>3</sup>	Schroeven	1 x 12,5mm Gyproc A	43 (-3;-9) *
6	JuuNoo 75mm	50 mm rotswol 33kg/m <sup>3</sup>	Schroeven	2 x 12,5mm Gyproc A	49 (-2;-9) *
7	JuuNoo 75mm	50 mm rotswol 33kg/m <sup>3</sup>	Schroeven	1 x 12mm OSB + 1 x 12,5mm Gyproc A	51 (-3;-10) *
8	JuuNoo 75mm	50 mm rotswol 33kg/m <sup>3</sup>	Schroeven	2 x 12,5mm Soundblock (gyproc)	56 (-3;-8)
9	JuuNoo 75mm	50 mm rotswol 33kg/m <sup>3</sup>	Schroeven	1 x 10mm Clickwall + 12mm Multiplex	50 (-3;-9)
10	JuuNoo 75mm	50 mm rotswol 33kg/m <sup>3</sup>	Schroeven	1 x 12mm OSB + 1 x 12,5mm Soundblock	55 (-3;-9)
11	JuuNoo 75mm	50 mm rotswol 33kg/m <sup>3</sup>	Schroeven	3 x 12,5mm Gyproc A	60 (-3;-8)
12	JuuNoo 75mm	50 mm rotswol 33kg/m <sup>3</sup>	Schroeven	1 x 12mm OSB + 2 x 12,5mm Gyproc A	59 (-2;-7)
13	JuuNoo 75mm	50 mm rotswol 33kg/m <sup>3</sup>	Schroeven	3 x 12,5mm Soundblock	61 (-3;-7)
14	2 x JuuNoo 75mm (ontdubbeld, zonder verbinding intern)	75 mm rotswol 33kg/m <sup>3</sup>	Schroeven	1 x 8mm Spaanplaat + 1 x 10mm ClickWall	58 (-4;-11)
15	2 x JuuNoo 75mm	75 mm rotswol 33kg/m <sup>3</sup>	Schroeven	2 x 8mm Spaanplaat + 1 x 10mm ClickWall	64 (-3;-11)
16	2 x JuuNoo 75mm	75 mm rotswol 33kg/m <sup>3</sup>	Schroeven	2 x 12,5mm Gyproc A	66 (-4;-11)
17	2 x JuuNoo 75mm	75 mm rotswol 33kg/m <sup>3</sup>	Schroeven	3 x 12,5mm Gyproc A	73 (-4;-11)
18	2 x JuuNoo 75mm	75 mm rotswol 33kg/m <sup>3</sup>	Schroeven	1 x 12mm OSB + 2 x 12,5mm Gyproc A	72 (-4;-11)
19	2 x JuuNoo 75mm	75 mm rotswol 33kg/m <sup>3</sup>	Schroeven	3 x 12,5mm Soundblock	75 (-4;-11)
20	2 x JuuNoo 75mm	75 mm rotswol 33kg/m <sup>3</sup>	Schroeven	1 x 12mm OSB + 2 x 12,5mm Soundblock	74 (-4;-11)
21	2 x JuuNoo 75mm	2 x 75 mm rotswol 33kg/m <sup>3</sup>	Schroeven	2 x 8mm Spaanplaat + 1 x 10mm ClickWall	66 (-4;-11)
22	2 x JuuNoo 75mm	2 x 75 mm rotswol 33kg/m <sup>3</sup>	Schroeven	3 x 12,5mm Soundblock	77 (-4;-11)
23	2 x JuuNoo 75mm	2 x 75 mm rotswol 33kg/m <sup>3</sup>	Schroeven	1x 12mm OSB + 2 x 12,5mm Soundblock	76 (-4;-11)

\* Voor de wandssystemen 1 t/m 7 zijn de waarden gebaseerd op metingen in een geaccrediteerd akoestisch labo volgens ISO 10140-2

Detailed reports can be requested from the JUUNOO technical service department via email [info@juunoo.com](mailto:info@juunoo.com).

10.1.1 BaseClick wall

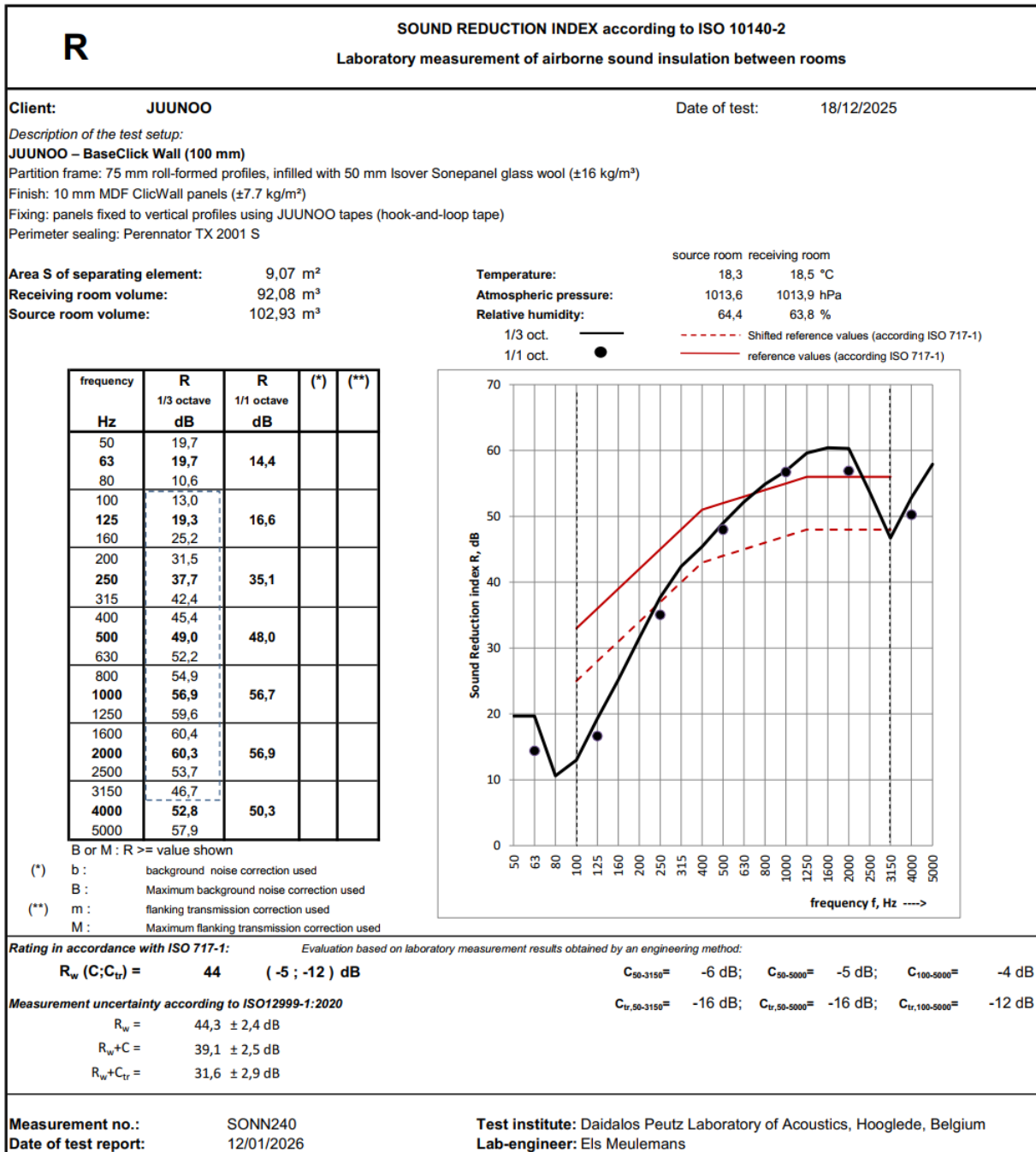

10.1.2 AcouClick wall

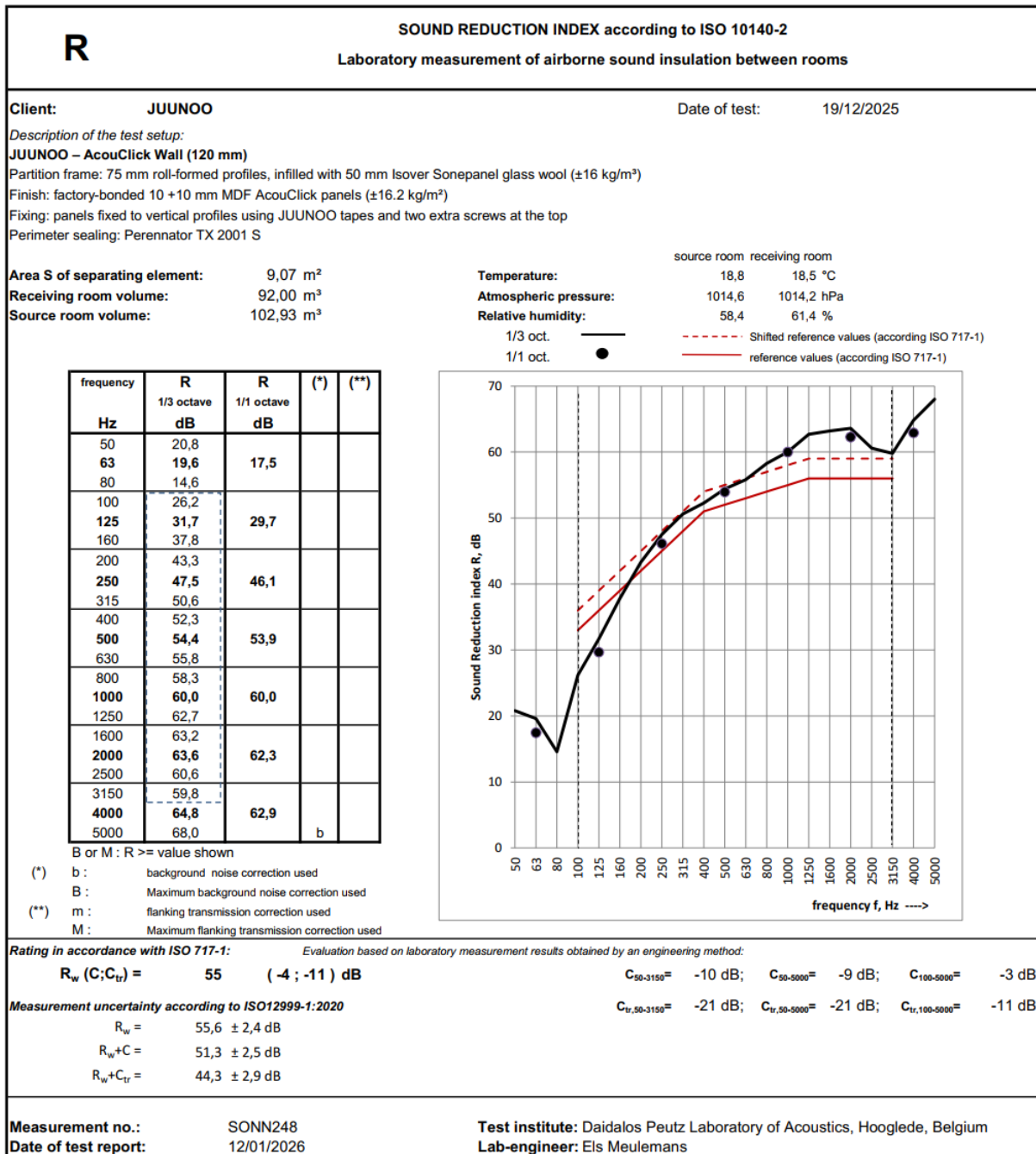

10.2

Glas type	Rw (C; Ctr)	Aansluitend op ...
Single 66.2A Profile width: 30 mm	<b>36 (0; -3) dB</b>	BaseClick wall
Single 66.2 Profile width: 30 mm	<b>35 (-2; -3) dB</b>	BaseClick wall
Single 88.2A Profile width: 30 mm	<b>38 (-1; -3) dB</b>	BaseClick wall
Single 88.2 Profile width: 30 mm	<b>37 (-2; -4) dB *</b>	BaseClick wall
Double 66.2 Cavity: 84 mm Profile width: 127 mm	<b>50 (-2; -6) dB</b>	AcouClick wall
Double 66.2A Cavity: 75 mm Profile width: 120 mm	<b>50 (-2; -8) dB</b>	AcouClick wall
Double 66.2A Cavity: 106 mm Profile width: 149 mm	<b>54 (-1; -6) dB *</b>	SilentClick wall
Double 88.2A Cavity: 80 mm Profile width: 127 mm	<b>54 (-1; -6) dB</b>	AcouClick wall
Double 88.2A Cavity: 102 mm Profile width: 149 mm	<b>57 (-3; -8) dB</b>	SilentClick wall
Double 66.2A+ 88.2A Cavity: 102 mm Profile width: 149 mm	<b>56 (-2, -7) dB</b>	SilentClick wall

\* These values are simulations.

Detailed reports can be requested from the JUUNOO technical service department via email [info@juunoo.com](mailto:info@juunoo.com).

10.2.1 JUUNOO Glass partition walls - Single 66.2A glass

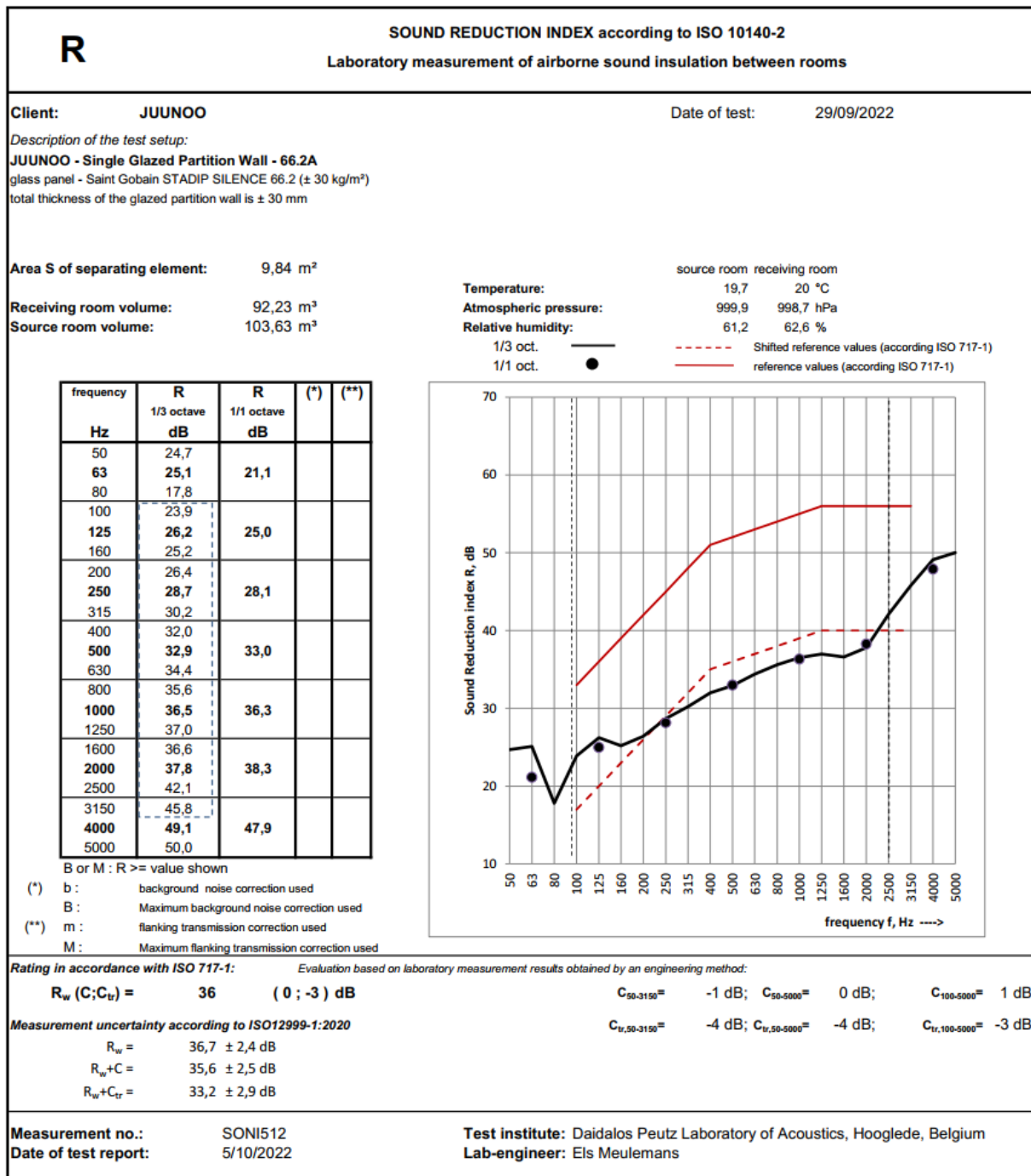

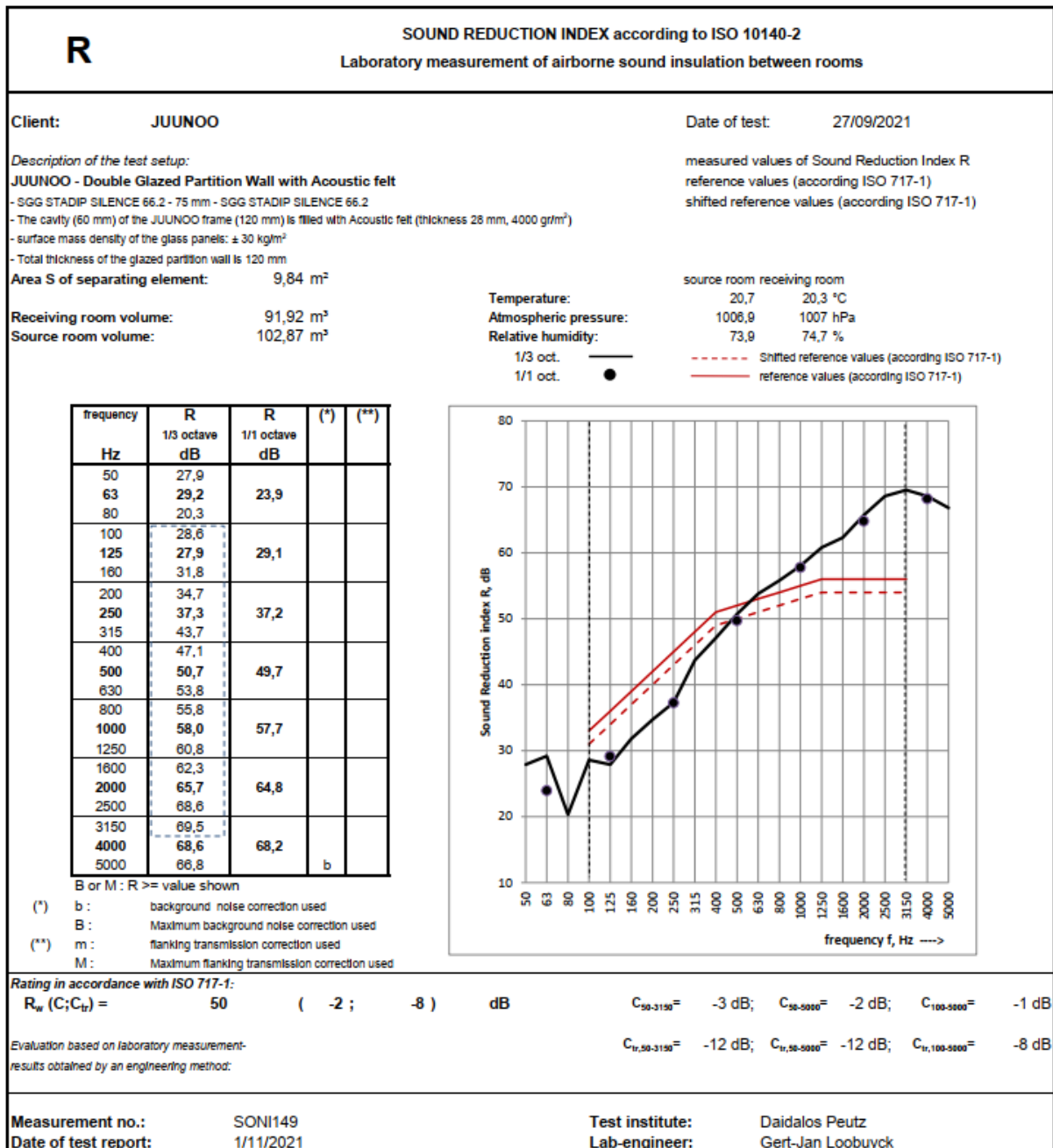

## 10.2.2 JUUNOO Glass partition walls – Double 66.2A glass



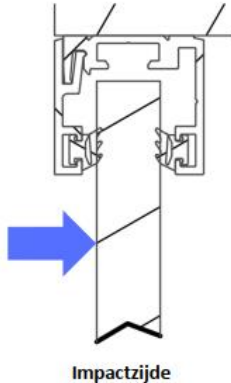

**PROEFVERSLAG**  
 DE-GSFM-0526  
 GSFM-21-236-02 (02)  
 BLZ. 4/7

10.3

RESULTATEN VAN DE PROEVEN		
Proeven met dubbele band		
Proef 1	schokproeven op glazen scheidingswand	
 <p>Impactzijde</p>		 <p>Impactplaats : midden van de beglazing</p>
Beglazing	- 66.2 (de zijden zijn afgeslepen)	
Montage	- Bovenprofiel is geschroefd. - Onderprofiel is met dubbelzijdig kleefband "JUUNOO Glue" op de grond gekleefd.	
Gebruik-categorie	Valhoogte (mm)	Opmerking
B	450	- Geen opmerking - Geen losse voorwerpen
C/D	700	- Geen opmerking - Geen losse voorwerpen
➤ <b>Classificatie: volgens TV 275: voldoet aan de eisen van categorieën A, B, C en D wanneer een doorvalrisico bestaat</b>		

4 SUMMARY

10.4

This document includes a comparative study between 4 different commercial interior wall systems in terms of mechanical strength and stiffness. The wall systems are typically used in combination with plasterboard. The wall systems that are compared in this study are:

- A wooden structure built from rectangular beams of 38 x 89 mm,
- A wooden structure built from rectangular beams of 38 x 58 mm,
- A Metal Stud structure, and
- The JuuNoo system

Testing methods for the determination of the strength and safety of interior partition walls in Belgium are given in the technical WTCB report TV 233 of December 2017. For this comparative study, three of those testing methods were considered:

- A dynamic load due to a collision of a heavy soft body,
- A vertical static eccentric load, and
- A differential pressure

The results are presented in Figure 1 and Figure 2 in which the different systems are ordered from best to worst.

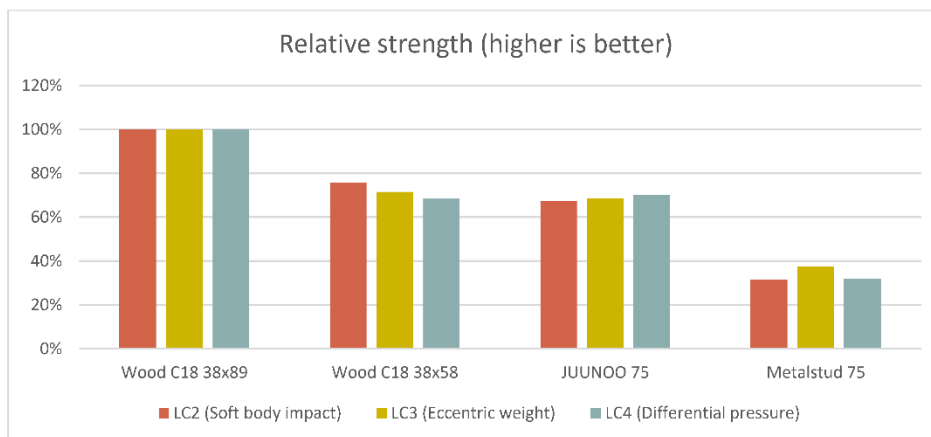

Figure 1 - Relative strength

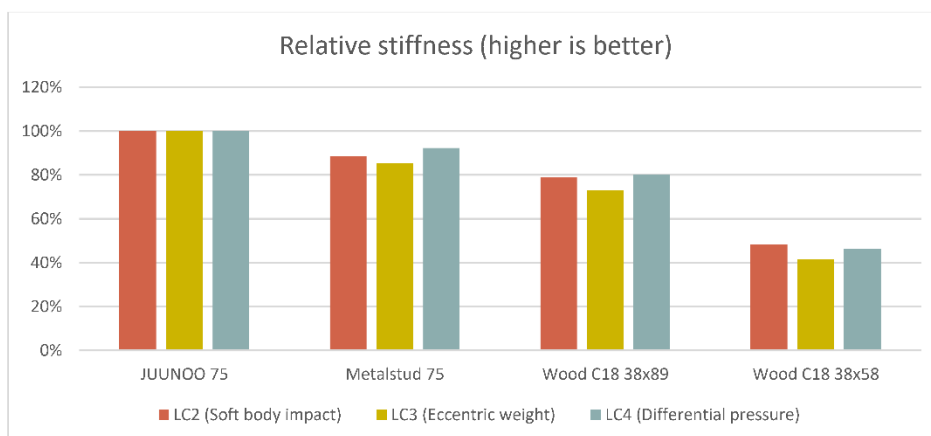

Figure 2 - Relative stiffness

10.5

### 3 Classification and field of application

#### 3.1 Reference of classification

This classification has been carried out in accordance with clause 7 of EN 13501-2:2016.

#### 3.2 Classification

The element, type: JuuNoo 75 mm structure + 2 x gypsumboard 12.5 mm, is classified according to the following combinations of performance parameters and classes as appropriate. No other classifications are permitted.

The classifications are valid for both sides of the non-loadbearing wall.

**EI 60 , EI 45, EI 30, EI 20, EI 15**

**EW 60, EW 30, EW 20**

**E 60, E 30, E 20**

10.6



**UNILIN**, division Panels

Ingelmunstersteenweg 229  
8780 Oostrozebeke – België  
+32 56 66 70 21

Oostrozebeke, 16/09/2019

Betreffende : UNILIN Clicwall gemonteerd op JuuNoo metalen structuur

Geachte,

Namens UNILIN Panels, bevestigen wij dat de JuuNoo metalen structuur in combinatie met UNILIN Clicwall panelen gebruikt kan worden.

Voor de JuuNoo metalen structuur zijn de aanbevelingen en condities voor plaatsing van toepassing, zoals beschreven in de algemene installatiegids voor metalen onderstructuren.

Indien verwerkt en geïnstalleerd volgens de richtlijnen, gelden de beloftes en garanties voor UNILIN Clicwall.

Hoogachtend,

A handwritten signature in black ink, appearing to read 'Heleen Verhamme', written over a horizontal line.

Heleen Verhamme  
Product Manager Clicwall

A handwritten signature in black ink, appearing to read 'Bénédicte Lobel', written over a horizontal line.

Bénédicte Lobel  
Business Manager Clicwall

UNILIN PANELS  
[www.unilinpanels.be](http://www.unilinpanels.be)



10.7

Kallo, 30 april 2019

T.a.v.: JUUNOO  
Chris Van de Voorde

Betreft: Gelijkwaardigheid vervanging Gyproc® Metal Stud® door JUUNOO-stijl

Hierbij bevestigen wij Saint-Gobain Gyproc®, dat de wandsystemen met door Juunoo ontworpen metalen structuur, gelijkwaardige resultaten behalen op het vlak van:

- Stabiliteit
- Akoestiek
- Brandweerstand

als de overeenkomstige Gyproc®-systemen.

Dit geldt wanneer de systemen opgebouwd worden conform de richtlijnen en met producten van Gyproc®.

De bovenvermelde verklaring werd gebaseerd op basis van testen uitgevoerd bij zowel externe, geaccrediteerde labo's als in het testlabo van Gyproc® te Kallo.

Met vriendelijke groeten,

Gerrit Schepens  
Technical Support Manager Gyproc

Herman Van der Schoepen  
Key Account Manager Industry & Prefab



**Saint-Gobain Construction Products Belgium NV/SA**  
Sint-Jansweg 9 - B-9130 Kallo - Tel.: +32 (0)3 360 22 11 - Fax: +32 (0)3 360 23 80 - [www.gyproc.be](http://www.gyproc.be)  
BTW/TVA BE 0400.865.465 - RPR Dendermonde - ING 320-0069176-85 - IBAN BE 89 3200 0691 7685 - BIC BBRUBEBB  
A Saint-Gobain Company

## 11 Disclaimer

The information and technical specifications contained in this book are provided as a reference for the installation and use of JUUNOO systems. While every effort has been made to ensure the accuracy and reliability of the contents, this book may not reflect the most current version of the system or its documentation.

For the most up-to-date version of the technical details and specifications, please refer to the official website at [www.juunoo.com](http://www.juunoo.com). The latest information and updates regarding our system, including any corrections, improvements, or changes, are published exclusively on the website.

JUUNOO NV is not liable for any damages, losses, or other adverse outcomes that may arise from the use of outdated or incorrect versions of this book, including during installation or operation of the system. By using this book, the reader acknowledges that the physical version may not include the latest updates and agrees that JUUNOO will not be held responsible for any claims related to damages caused by relying on outdated information.

It is the responsibility of the user to ensure they are referring to the most current version of the technical documentation, which can always be accessed on our website. We strongly recommend consulting the website regularly for updates.

By using this book, you acknowledge and accept these terms.



## QUICK

Quick and easy installation without dust or noise



## ATTRACTIVE

Great quality and a great look matched with top acoustics



## CIRCULAR

Endless options to reuse in other set-ups, spaces or buildings

Based on your feedback, we are constantly updating our technical info. Therefore, this edition is probably already out of date when you get it in your hands. For the most recent version, we would like to refer you to [www.juunoo.com/technical](http://www.juunoo.com/technical)

Or scan:



JUUNOO NV  
BLOKKESTRAAT 51  
B – 8550 ZWEVEGEM

+32 (0)56 44 18 90  
INFO@JUUNOO.COM  
WWW.JUUNOO.COM

**JUUNOO**  
THE WALL  
THAT PAYS OFF.